

Specifications For WP Push Terminal Series

Project 项目	Parameter 参数
适用线材 Wire Range	AWG24#-16#
接触电阻 Contact Resistance	≤ 30mΩ
绝缘电阻 Insulation Resistance	≥ 100MΩ 500VDC
额定负荷 Rated load	AC 50V 3A

Project 项目	Parameter 参数
耐电压 Withstand Voltage	AC 500V(50Hz)/min
温度范围 Temperature	-40℃ ~ +75℃
电气寿命 Electric Life	≥ 10,000 Cycles
线保持力 Keep Wire Force	1Kgf

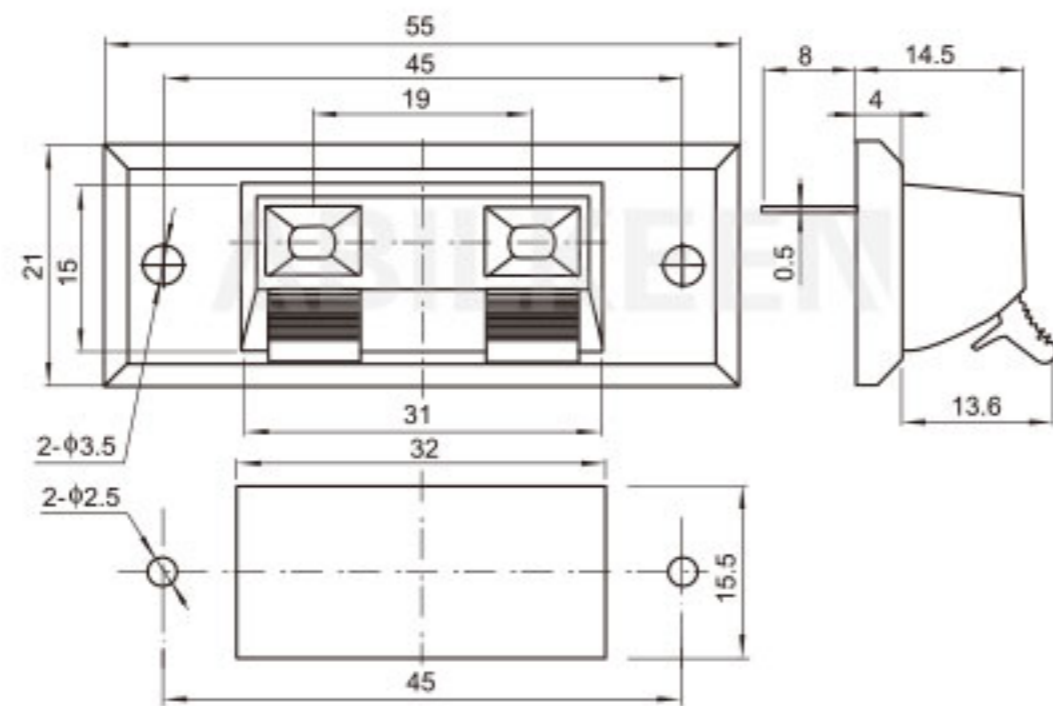
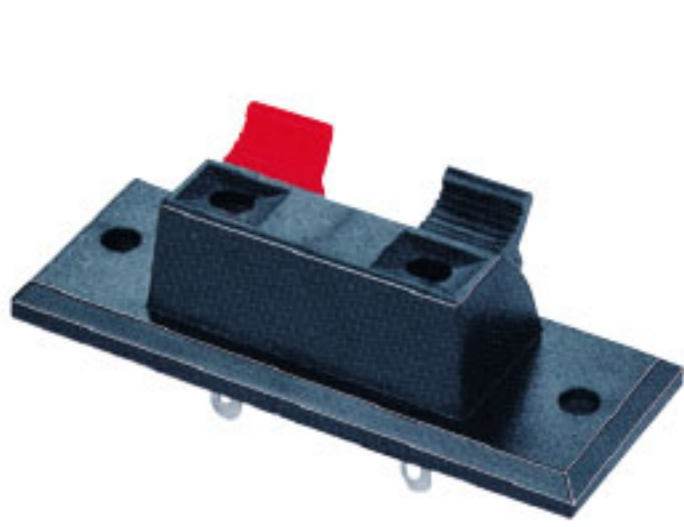

WP-002

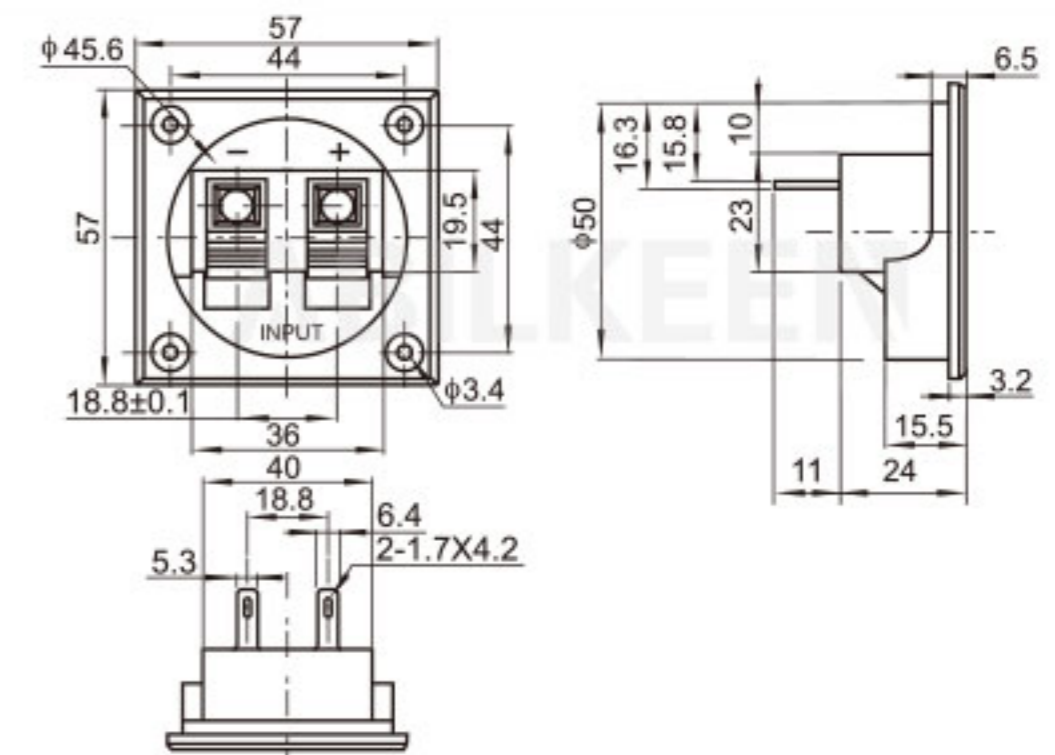

WP-010

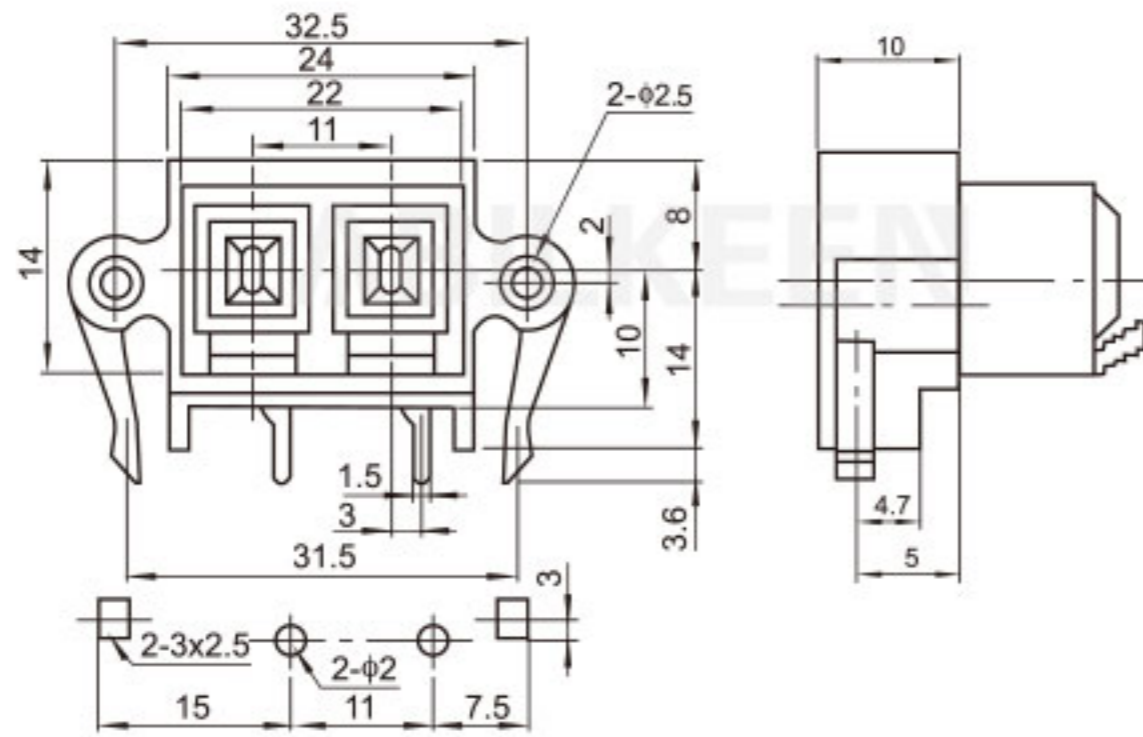
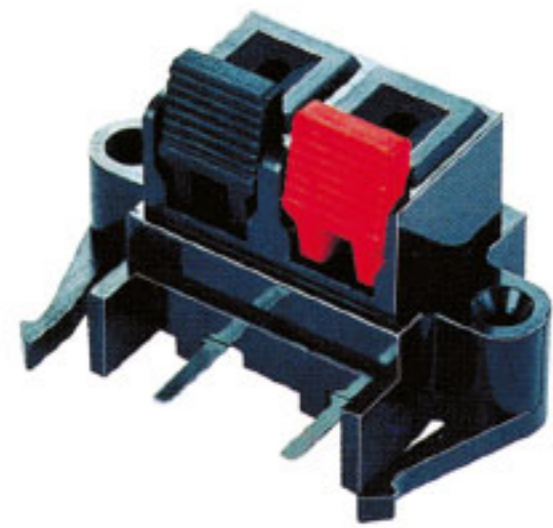

WP-003

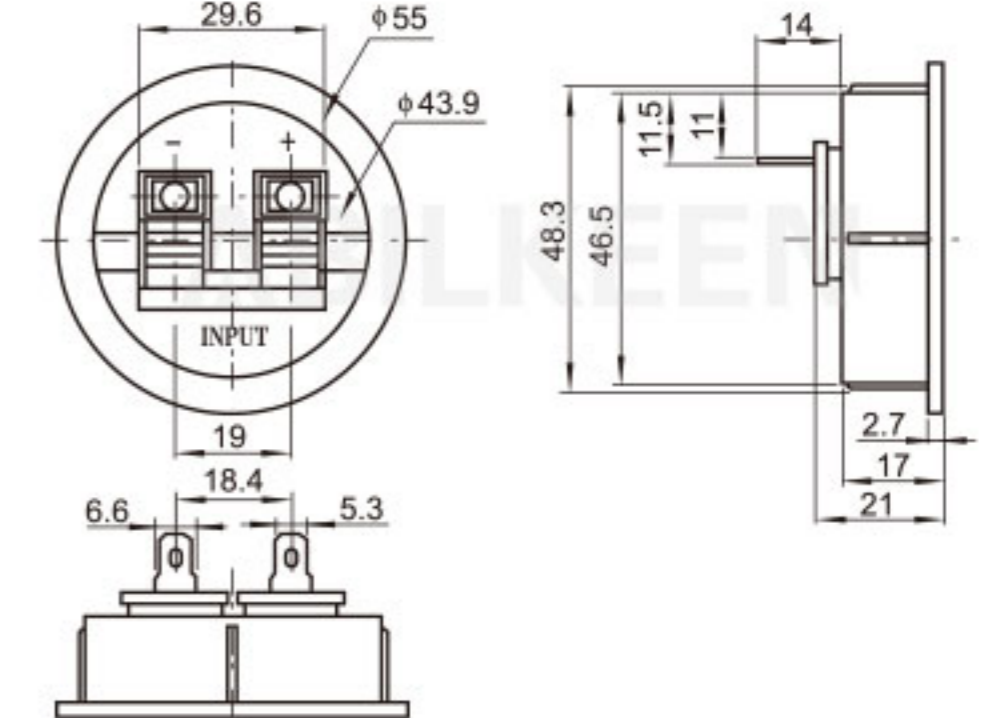

WP-011

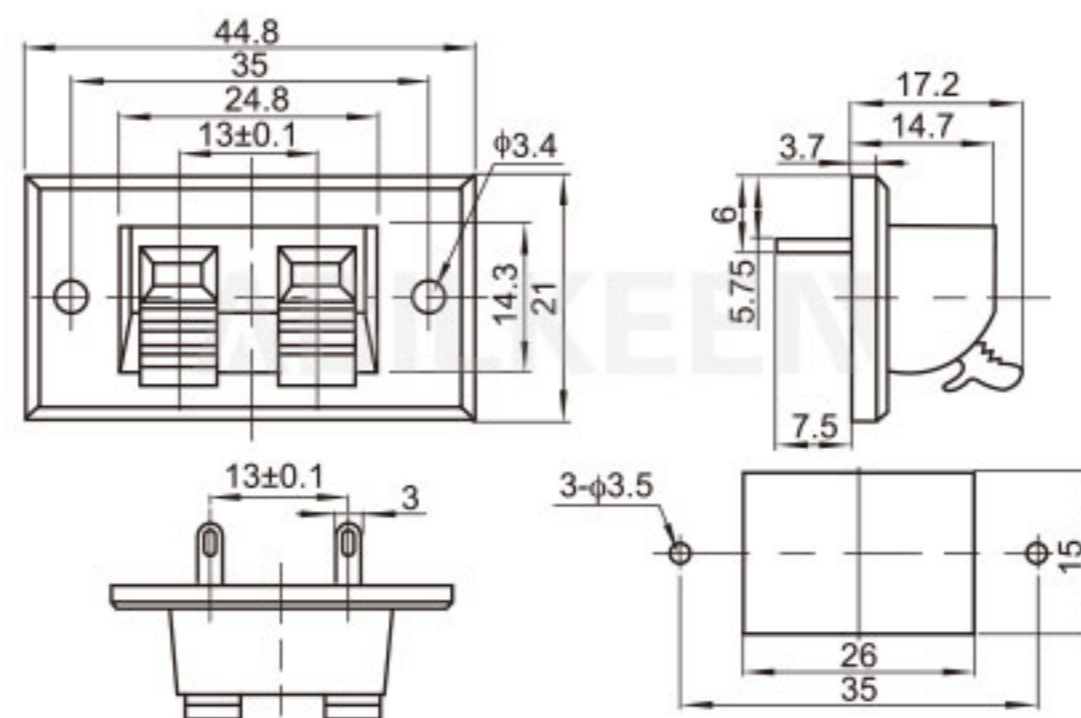

WP-004

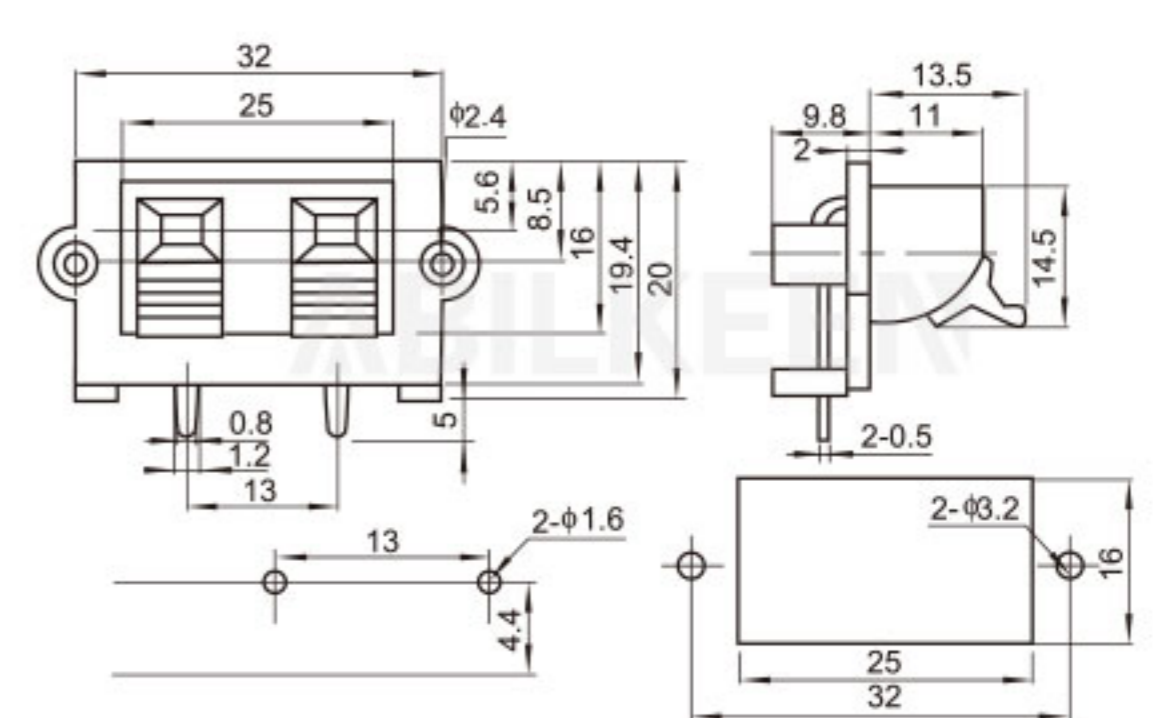

WP-013

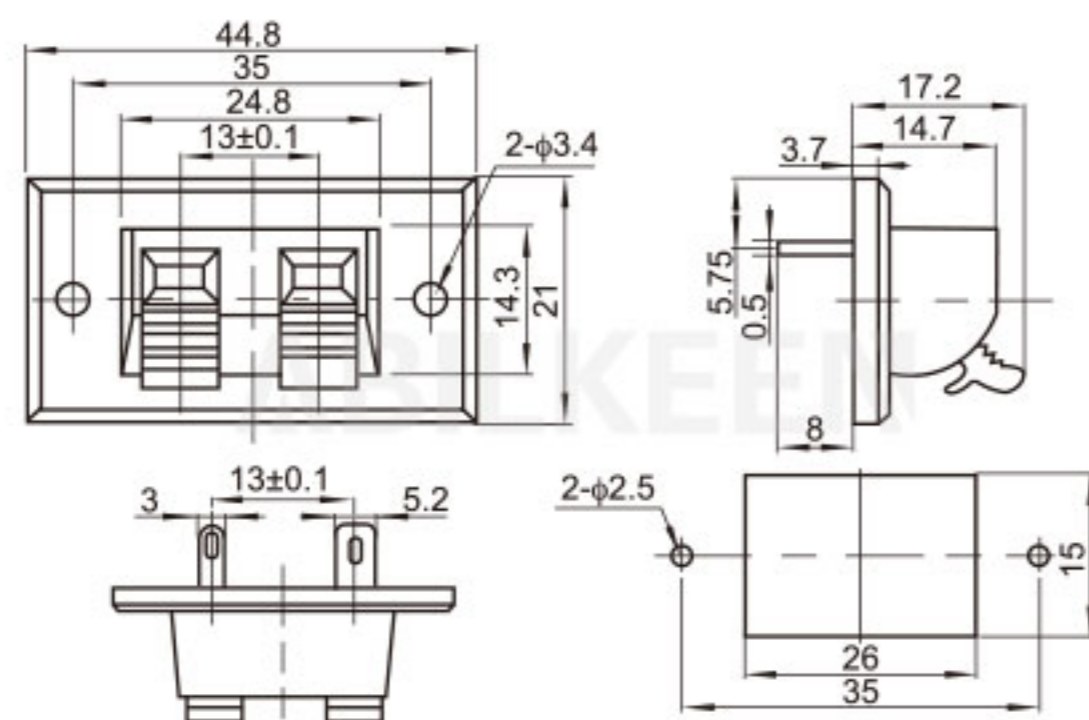
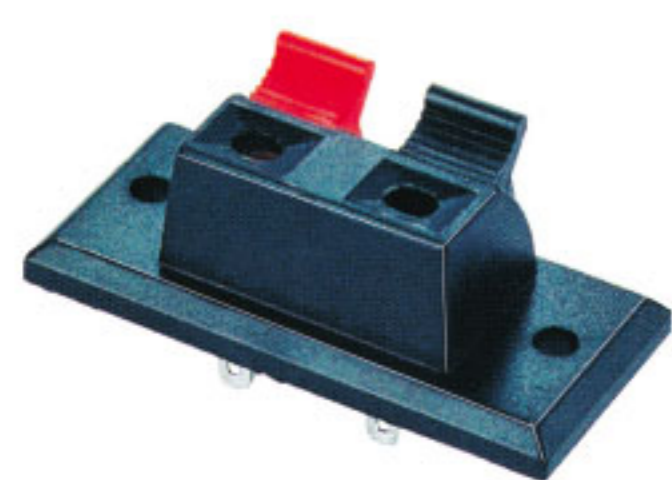

WP-005

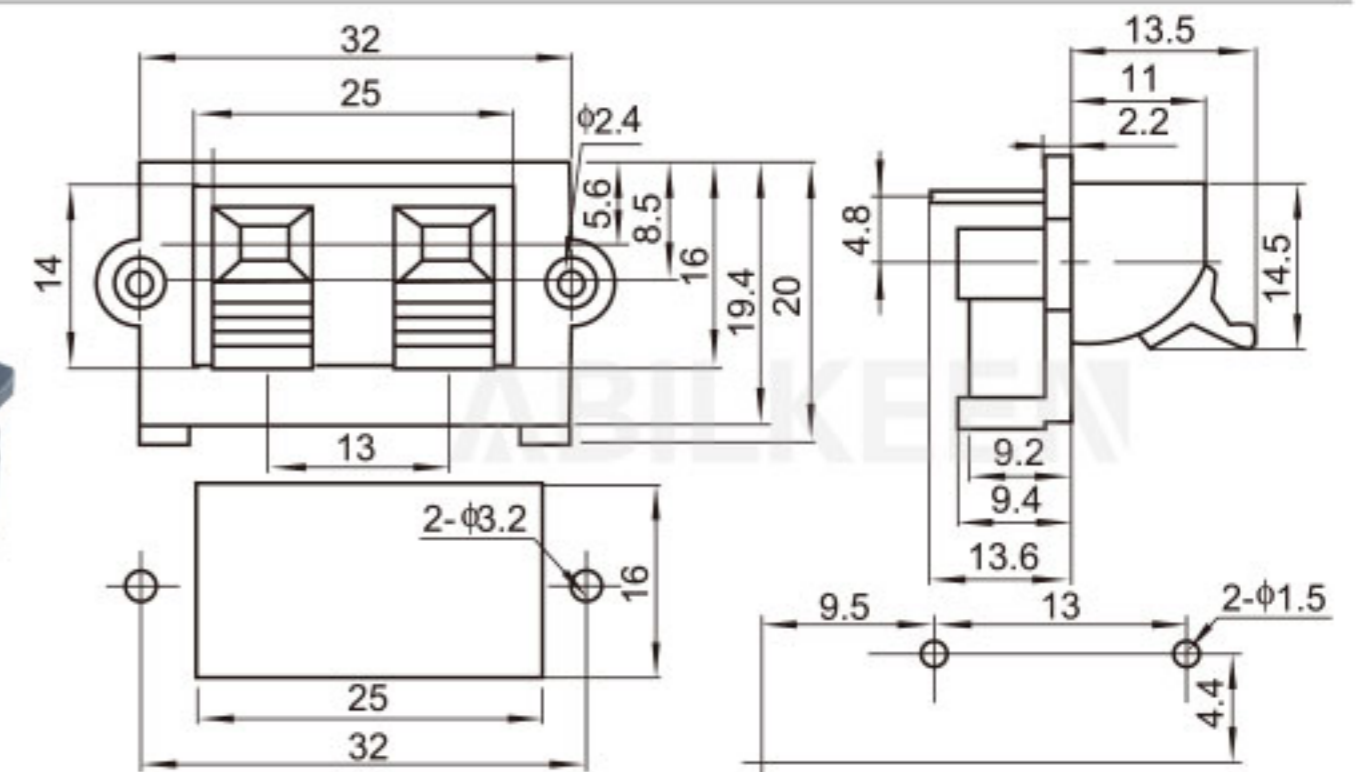

WP-014

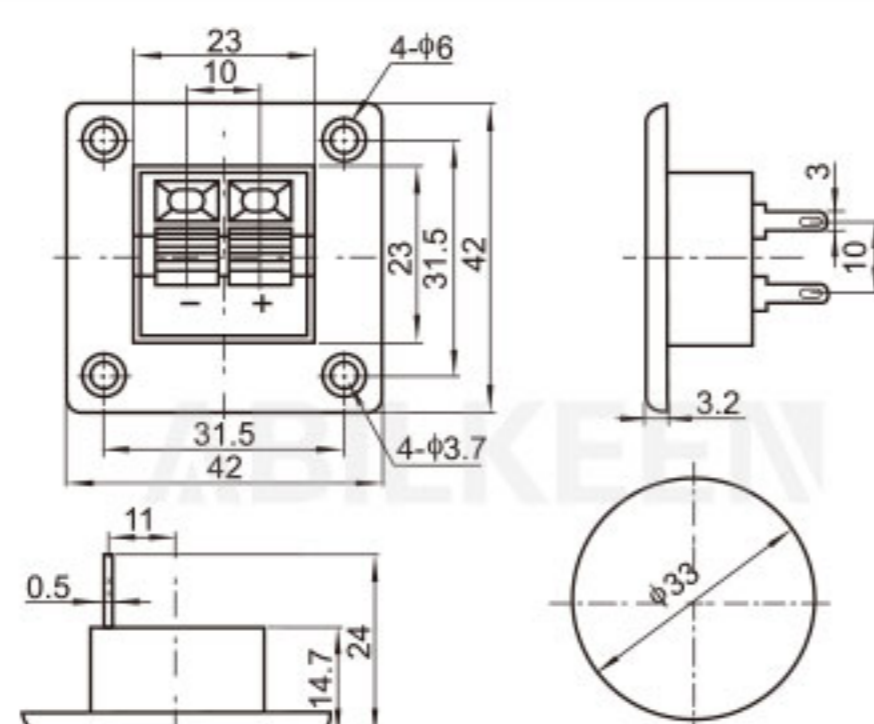
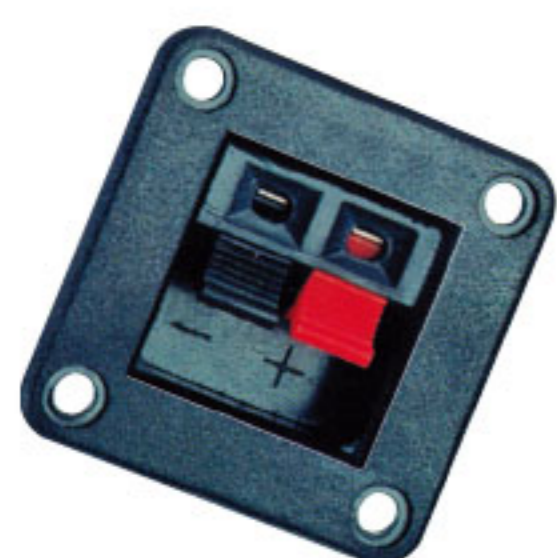

WP-007

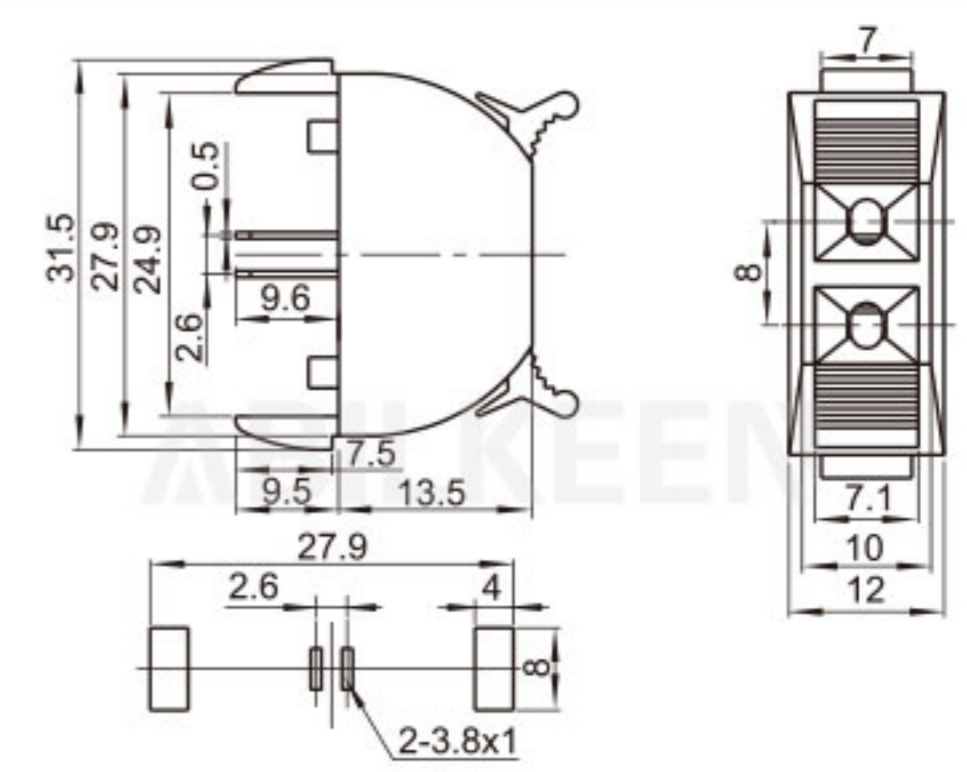

WP-017

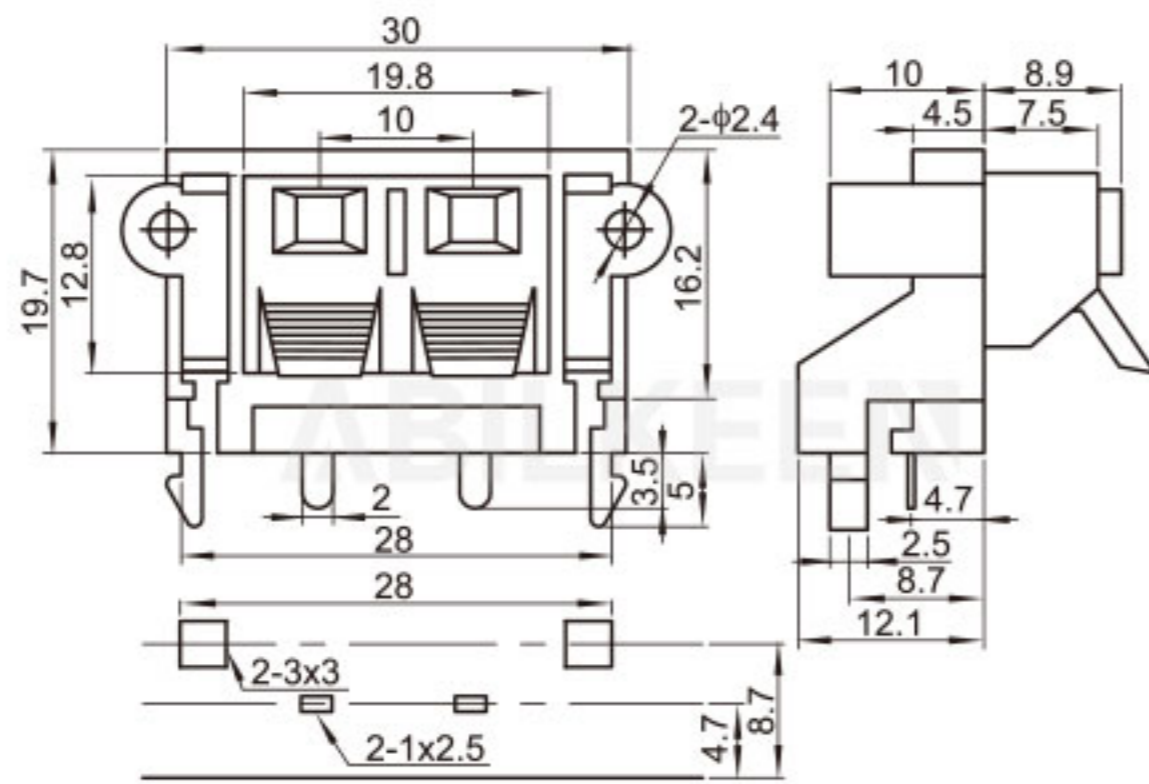
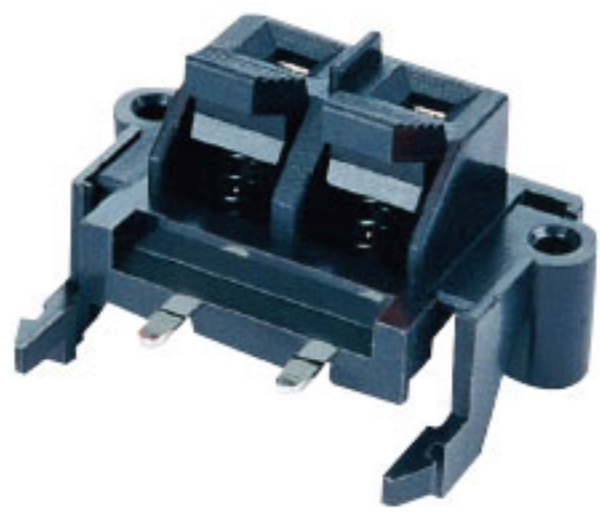

WP-022

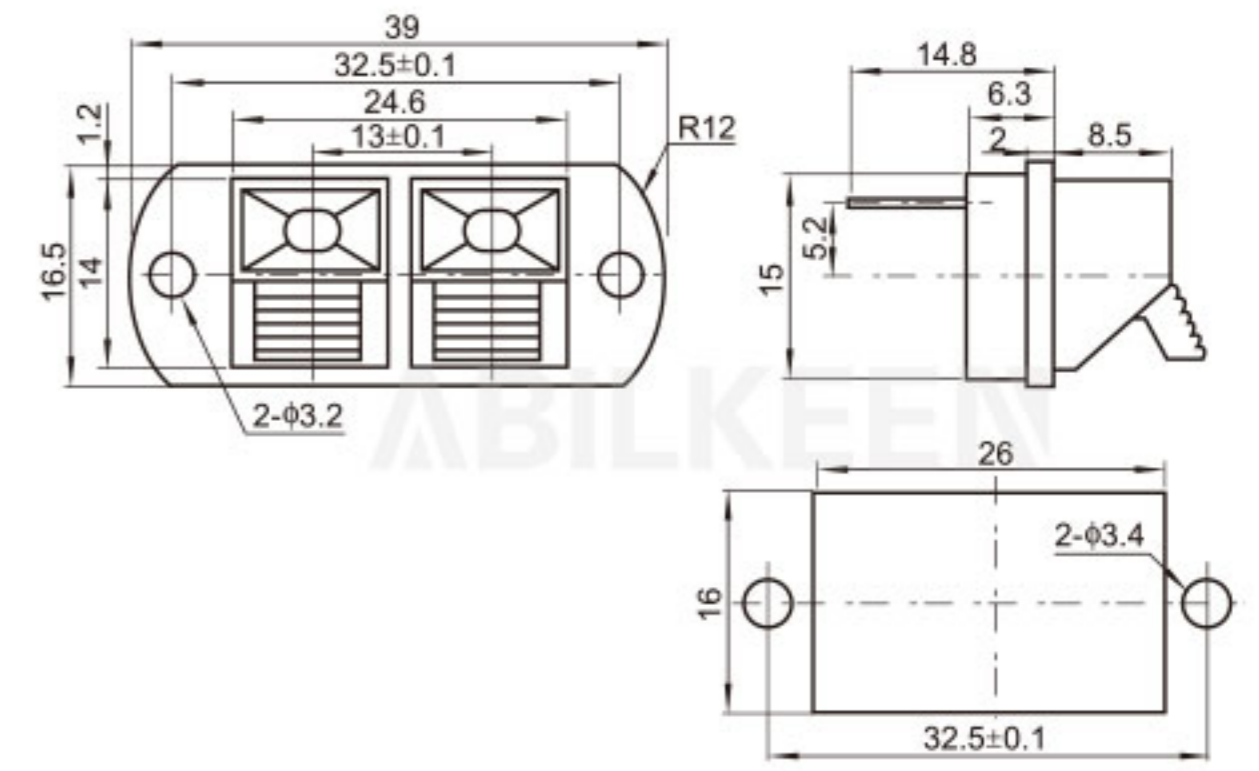

WP-032

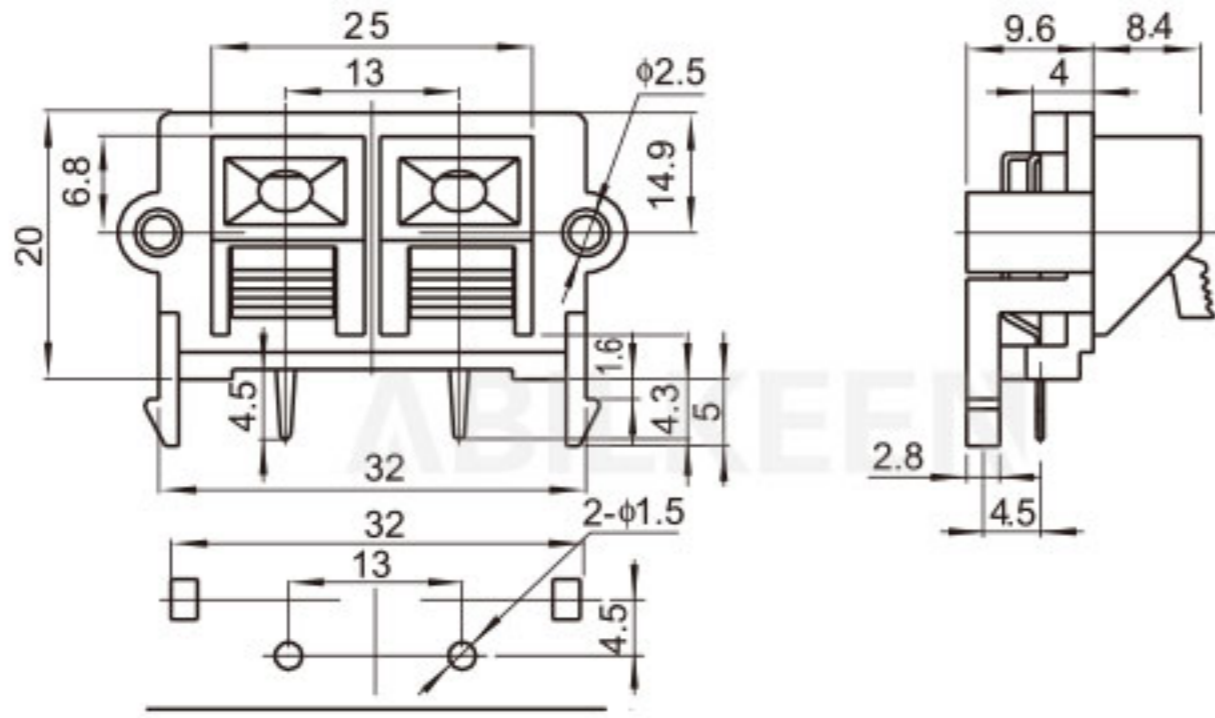

WP-023

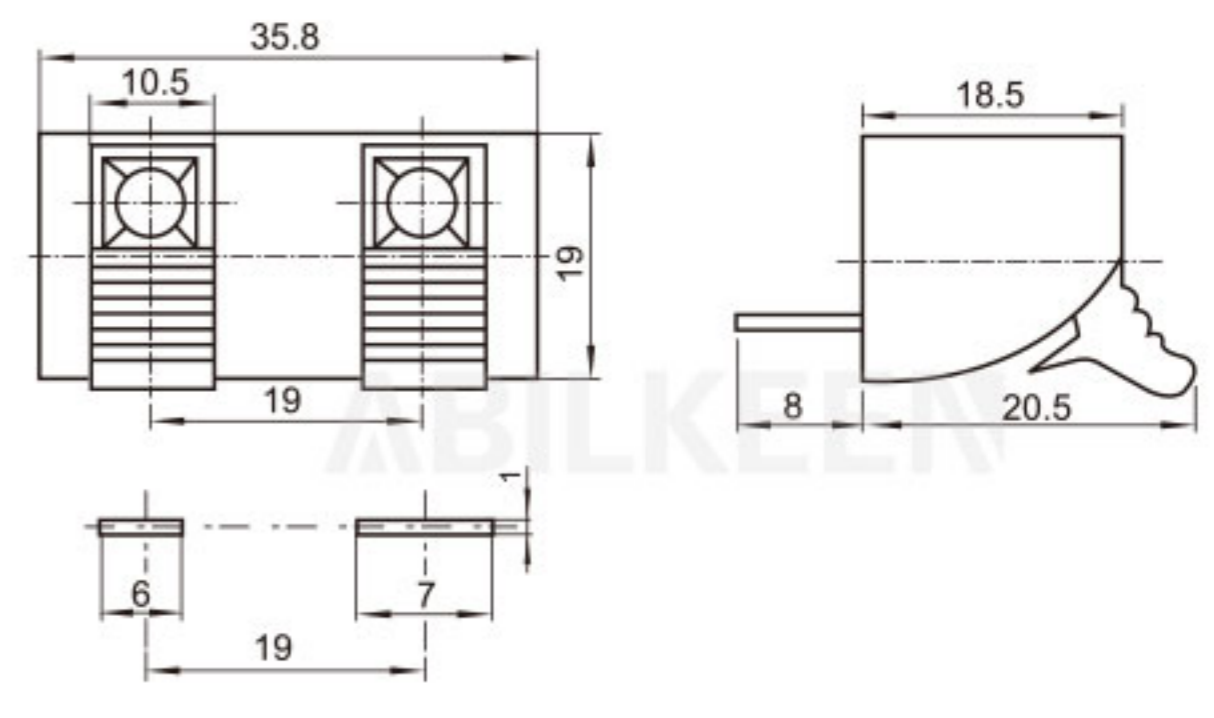

WP-033

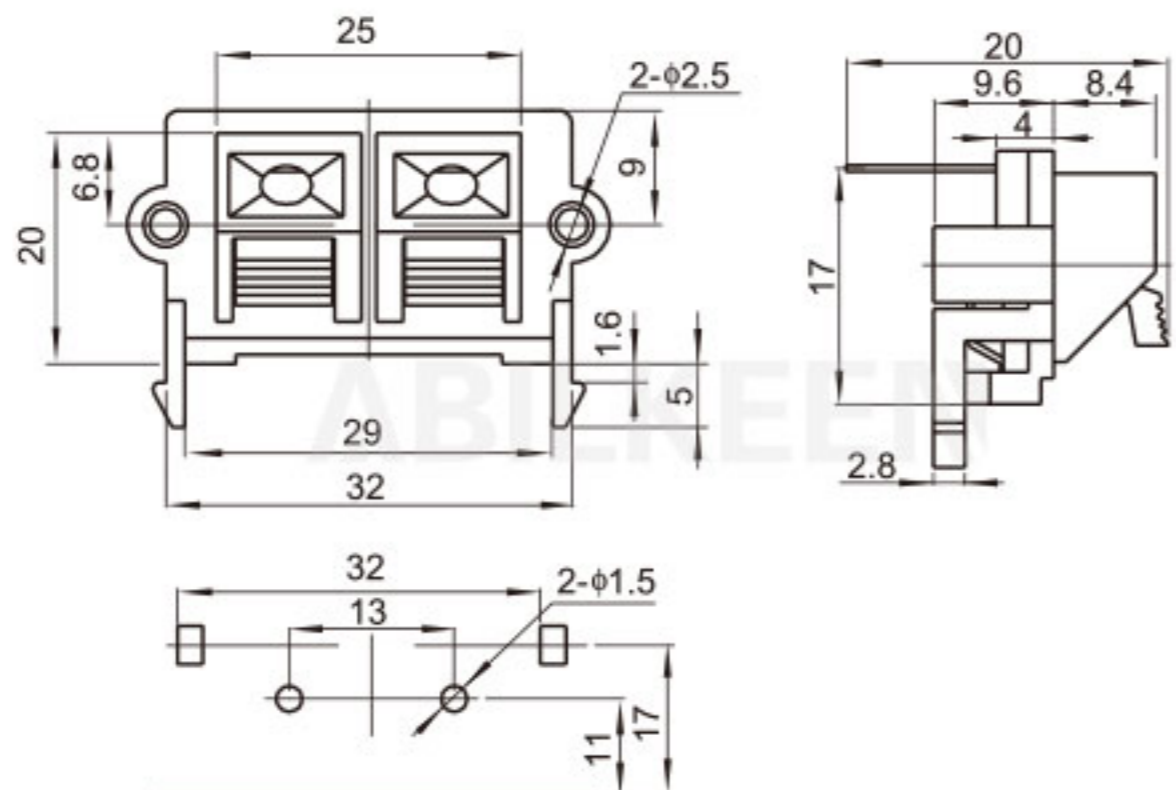

WP-024

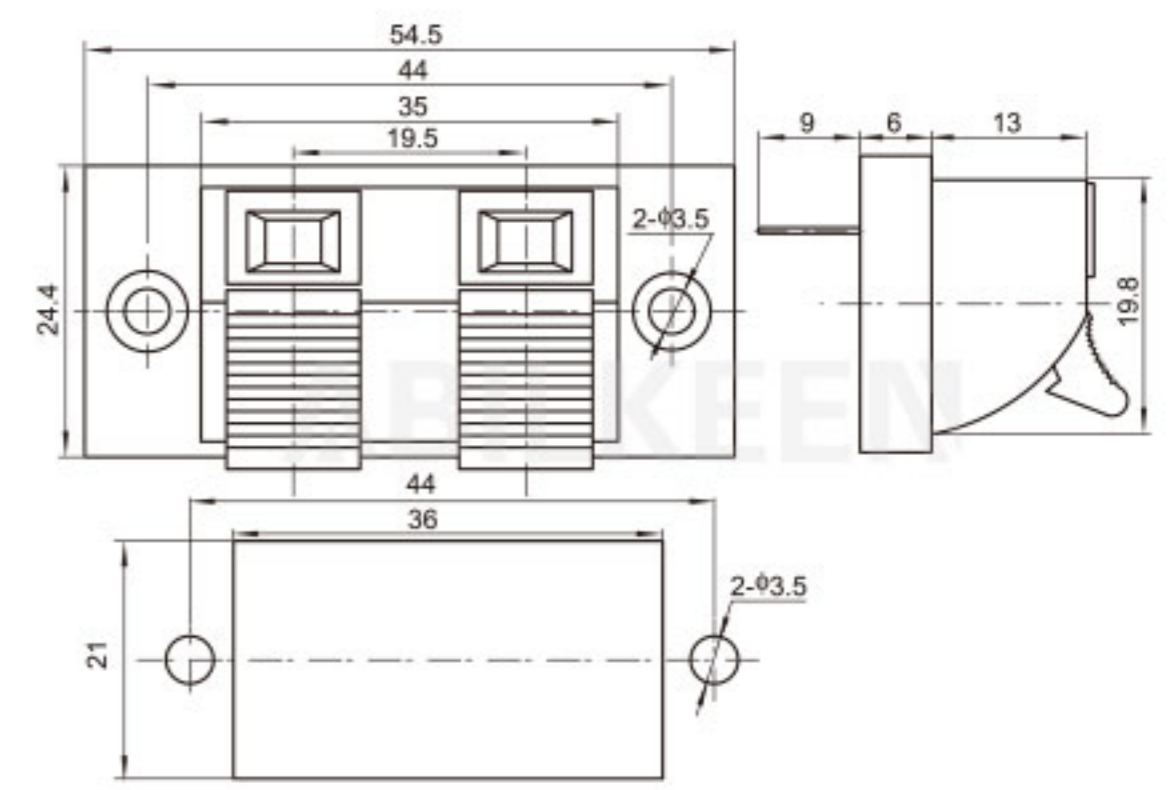
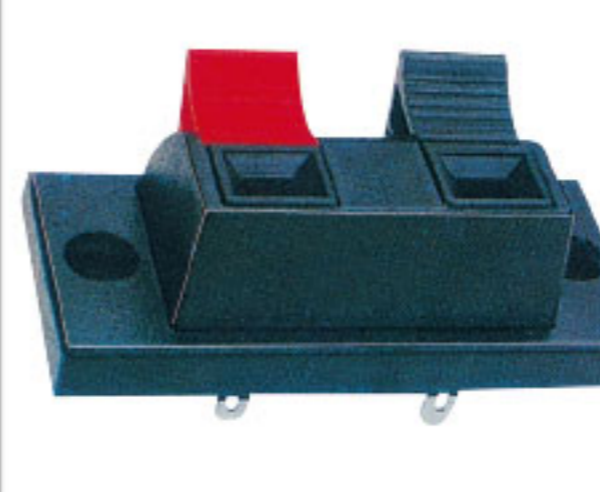

WP-035

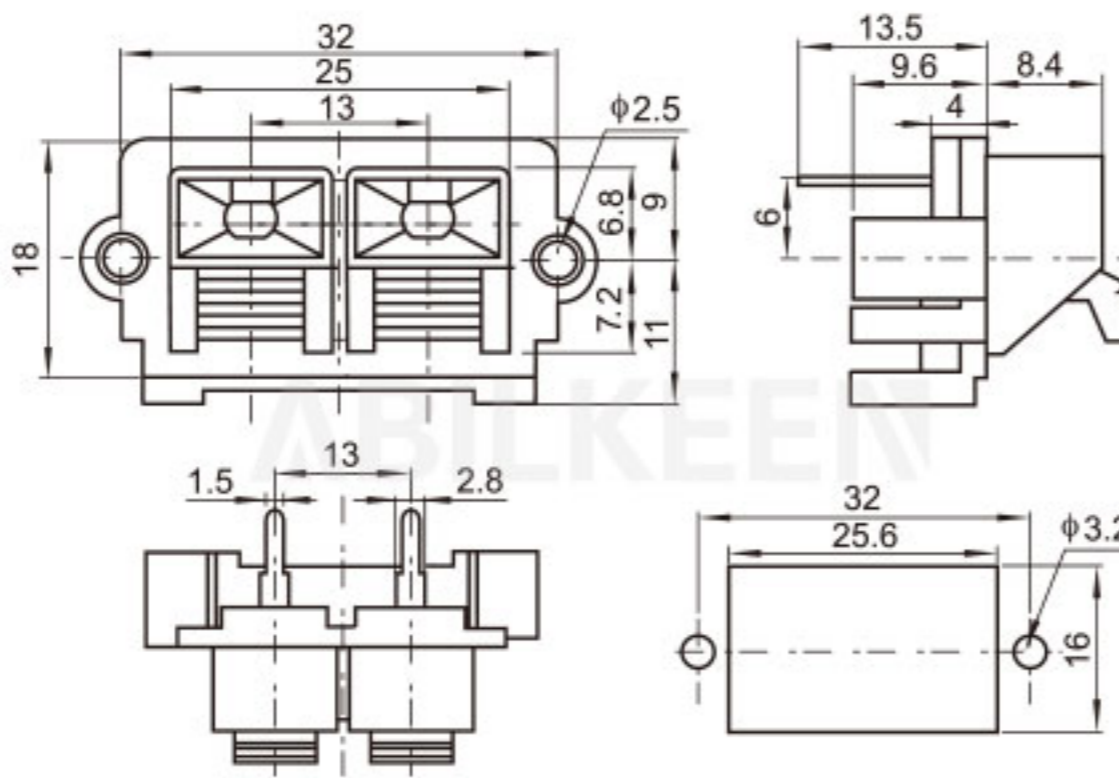
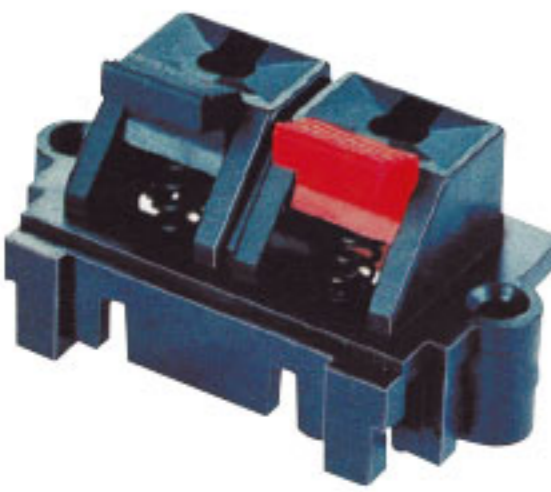

WP-025

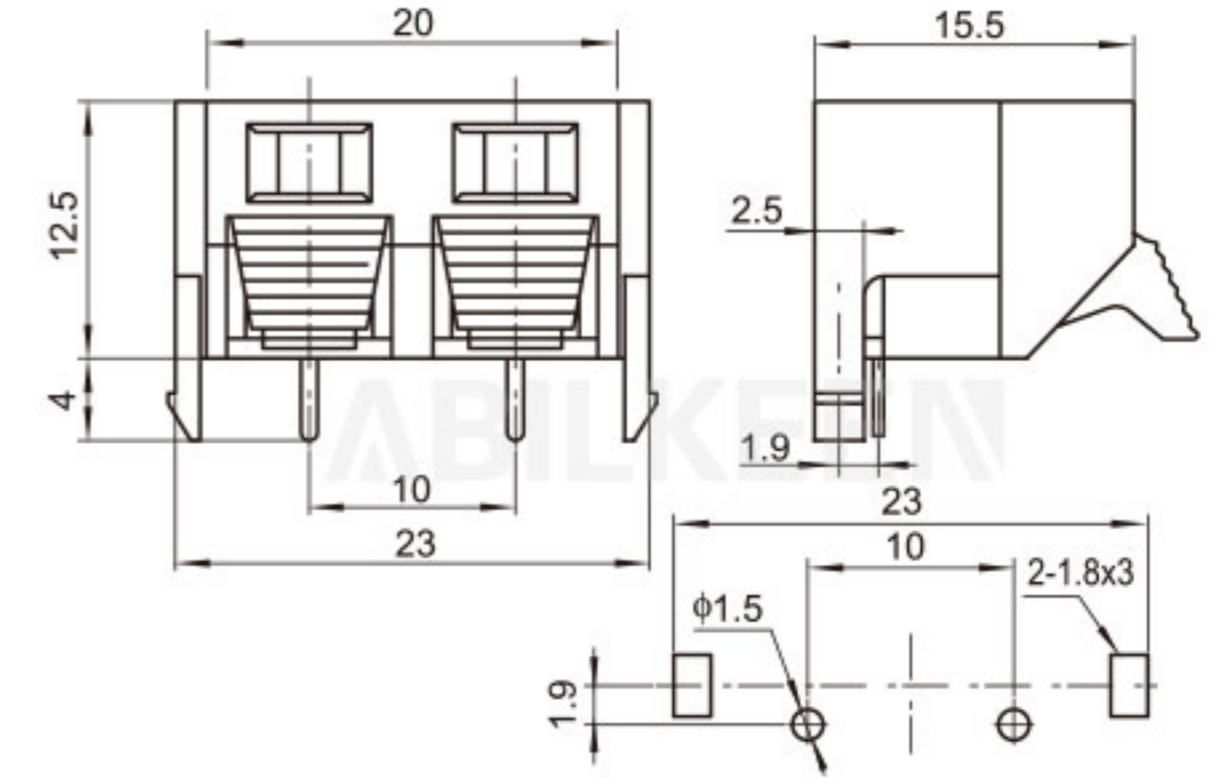
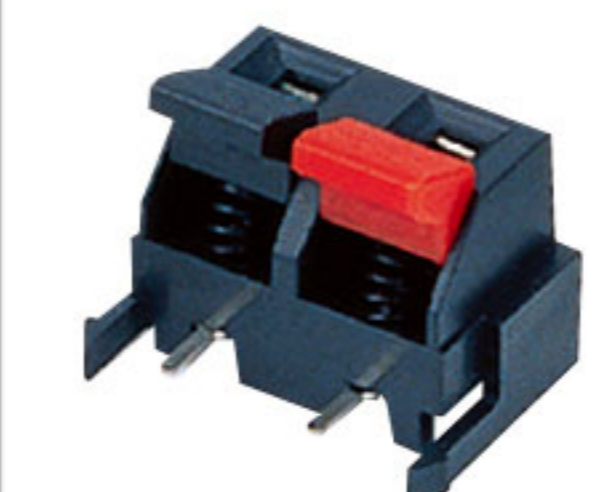

WP-037

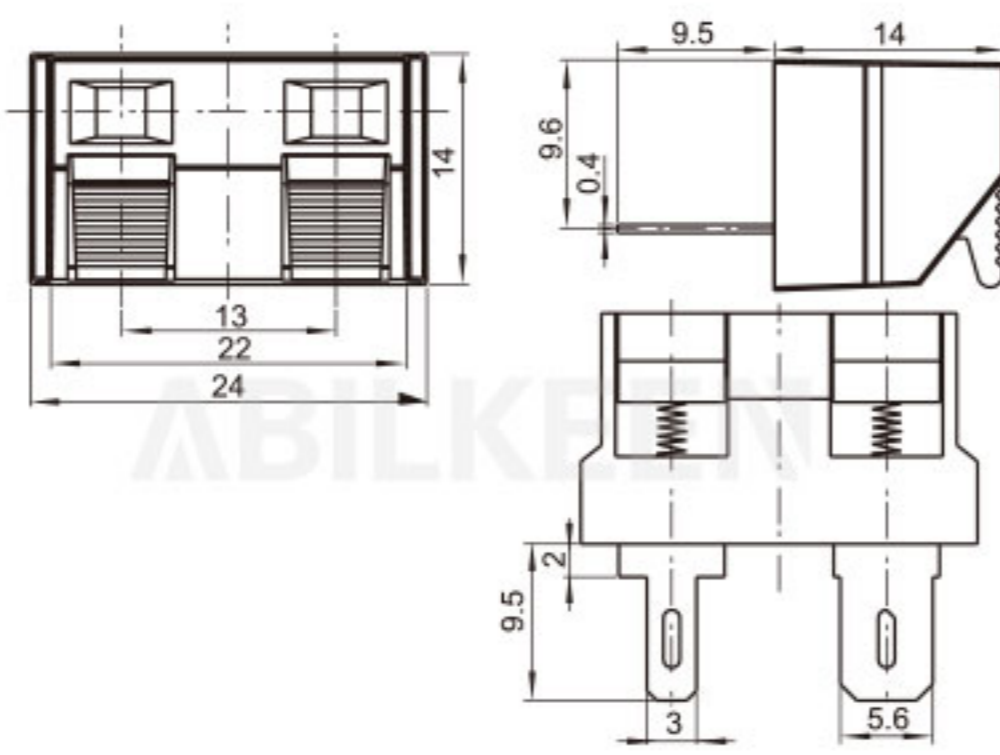
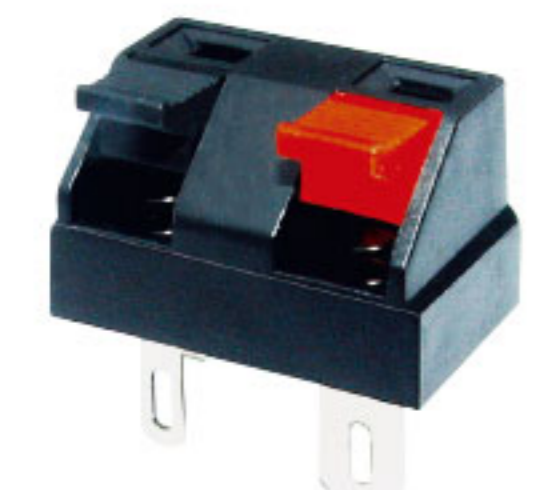

WP-029

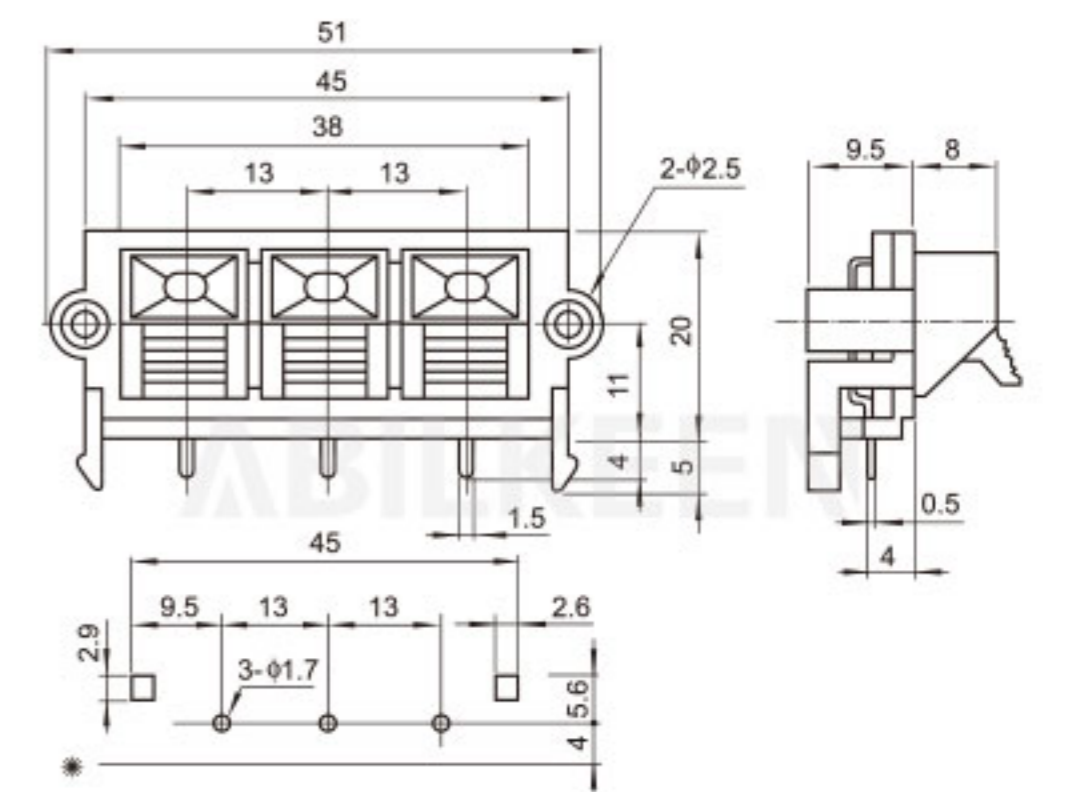
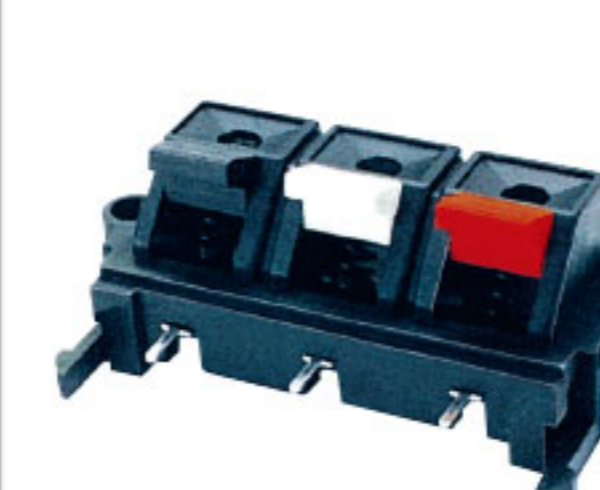

WP-042

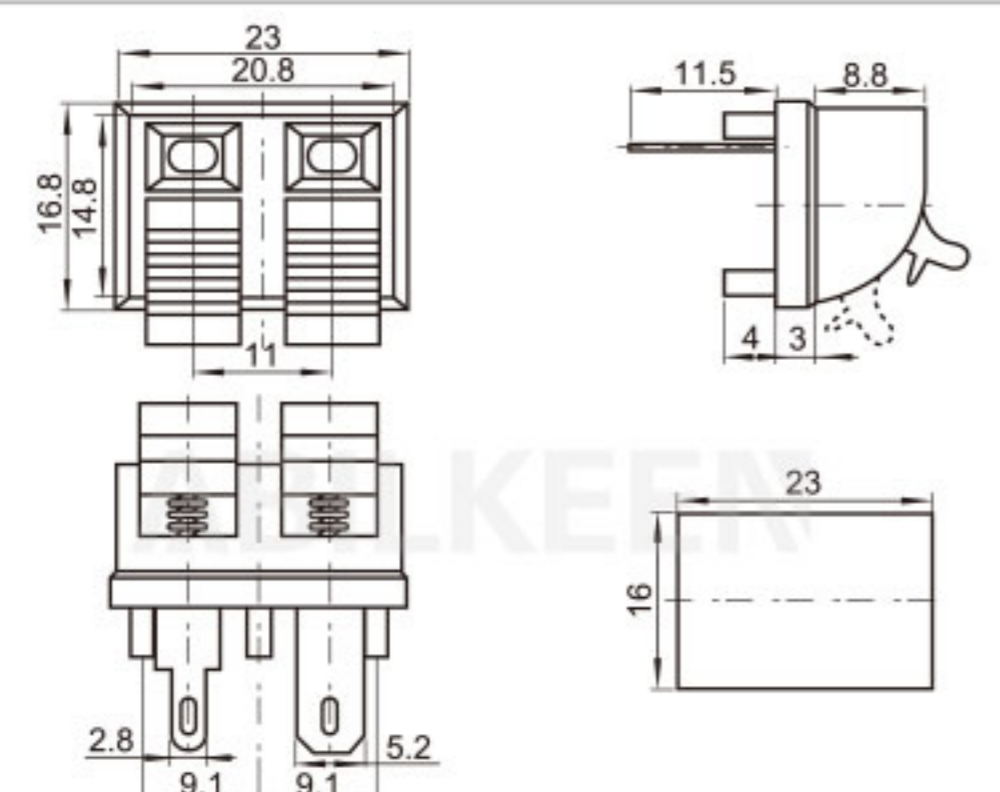

WP-030

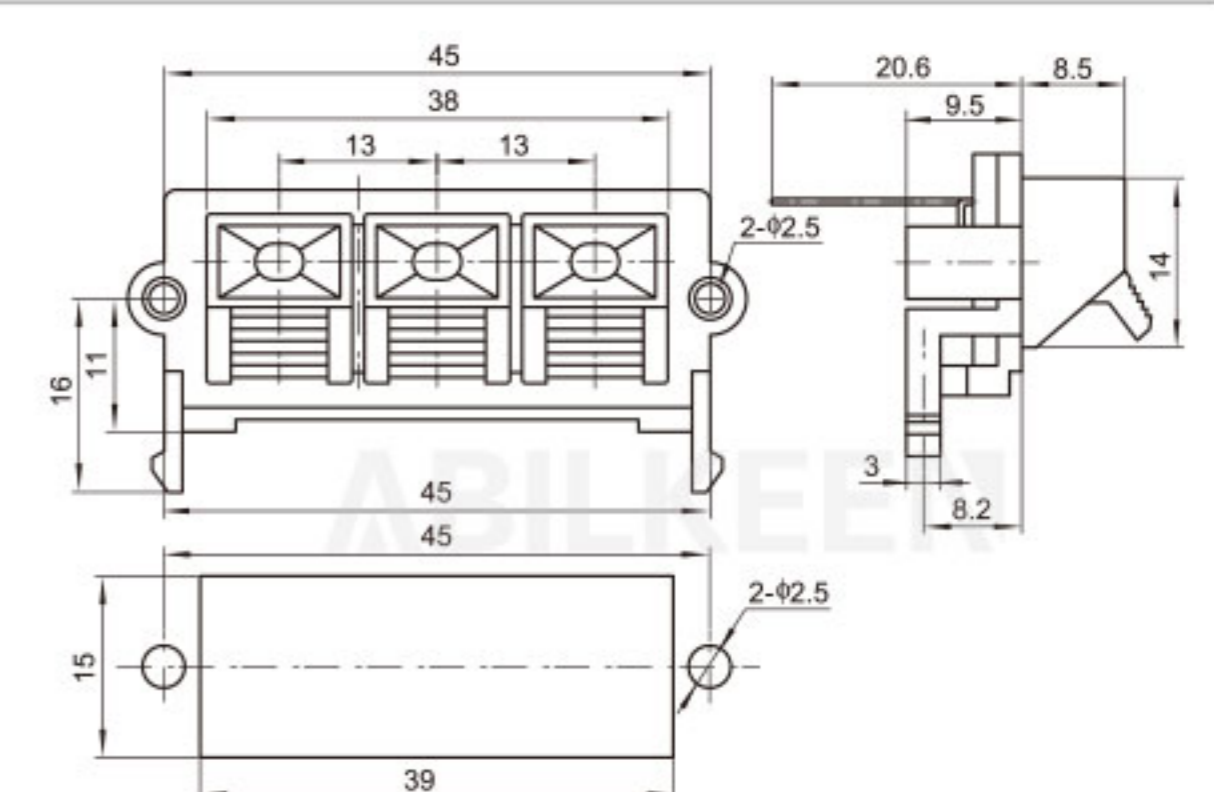

WP-043

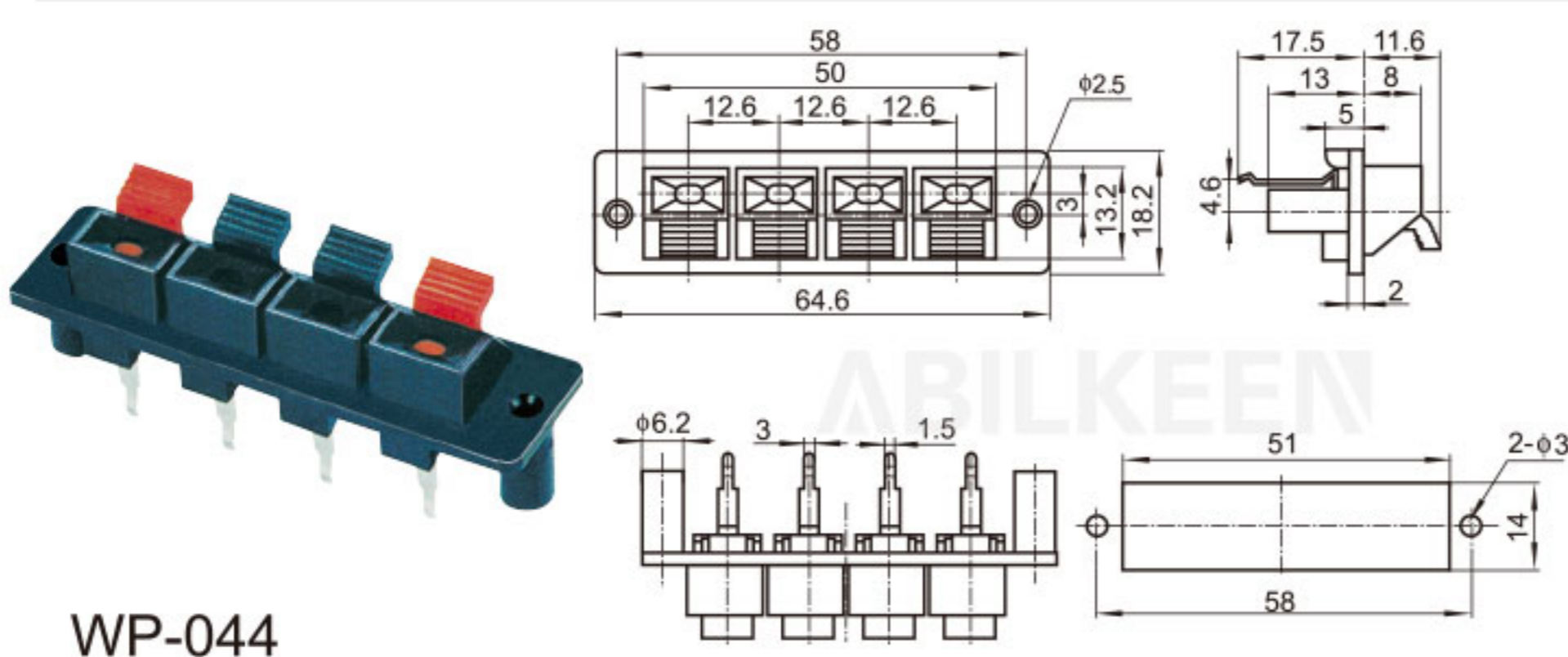

WP-044

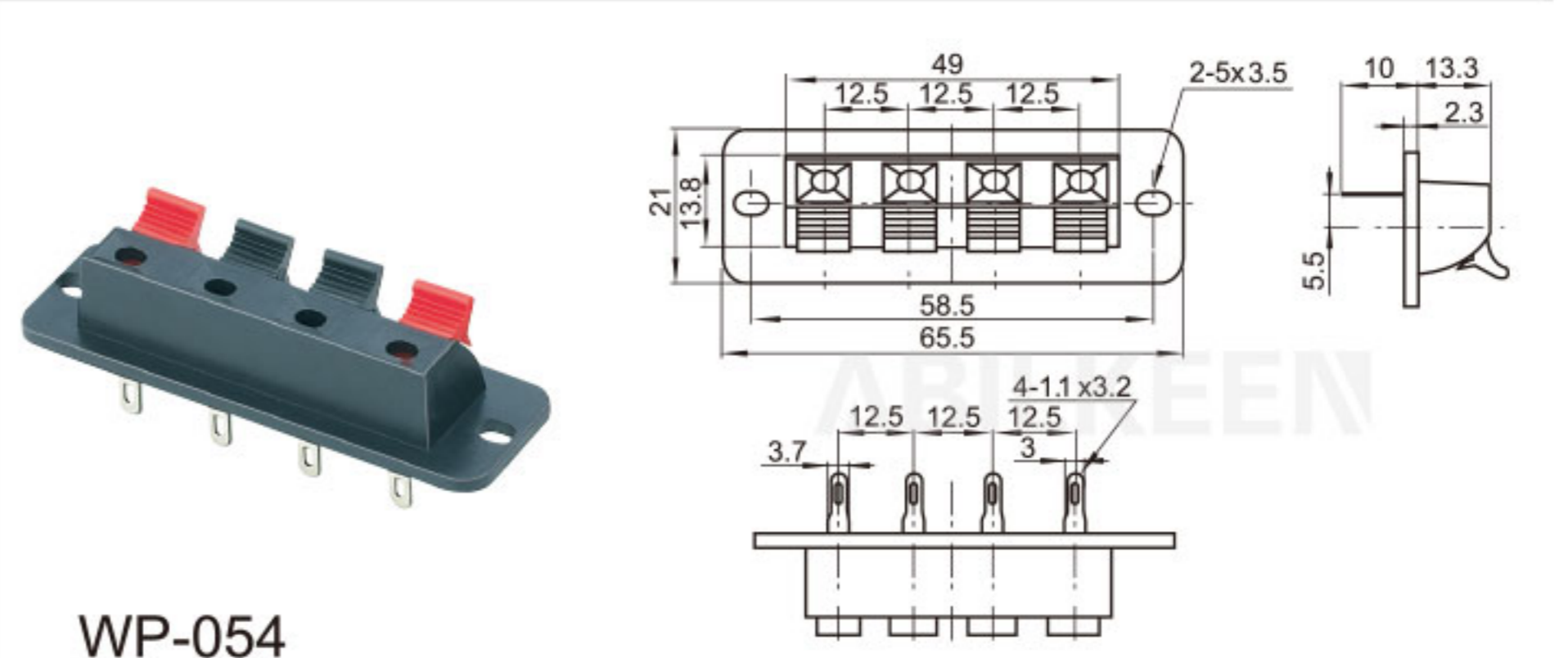

WP-054

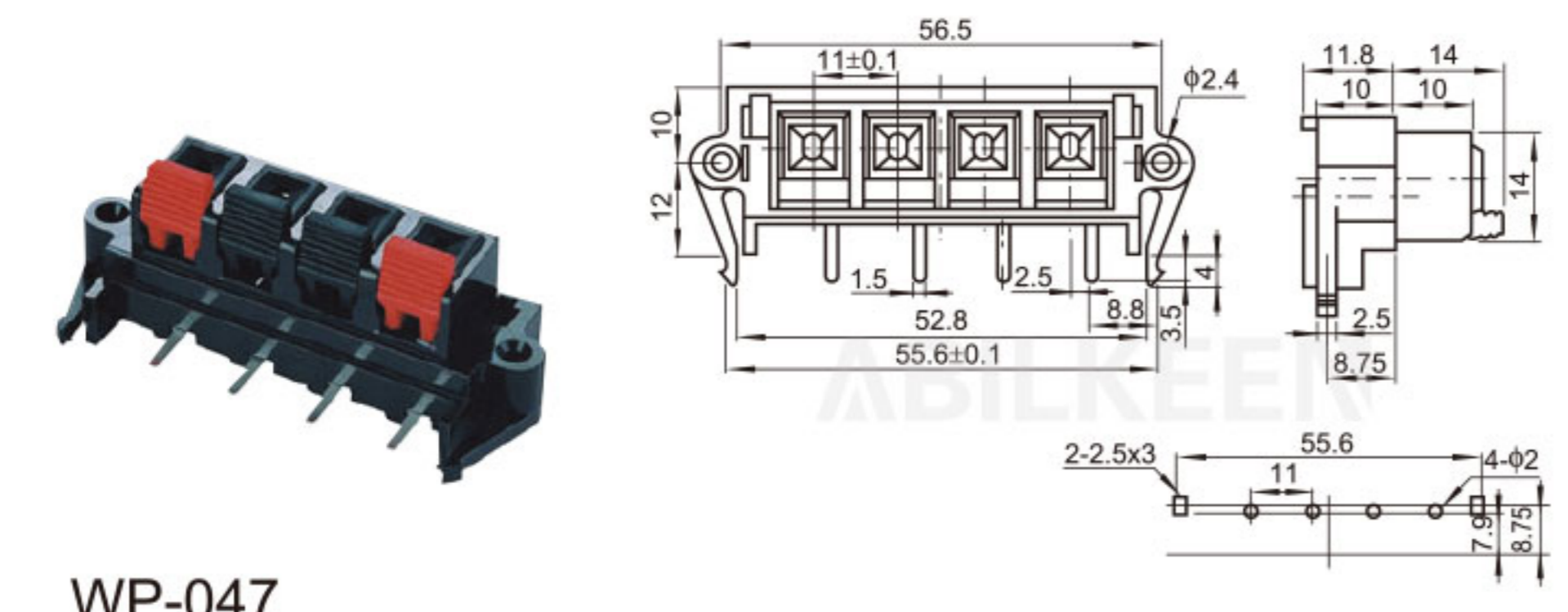

WP-047

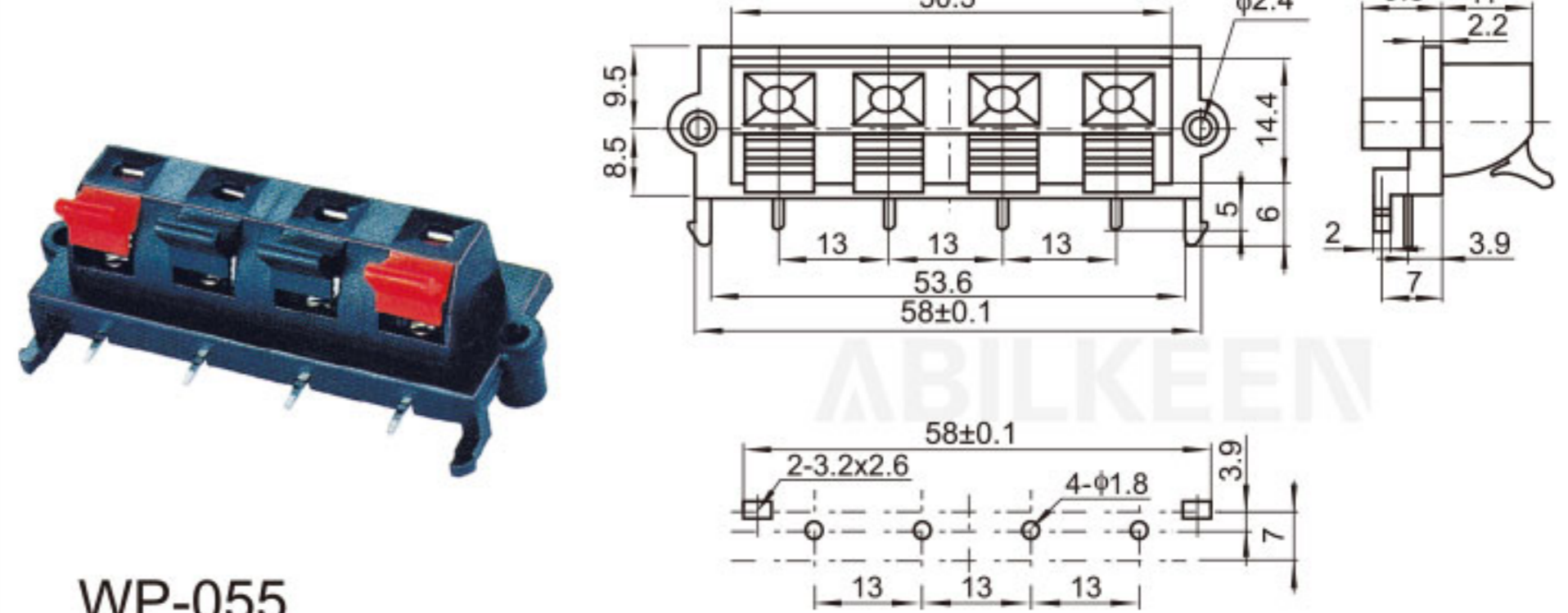

WP-055

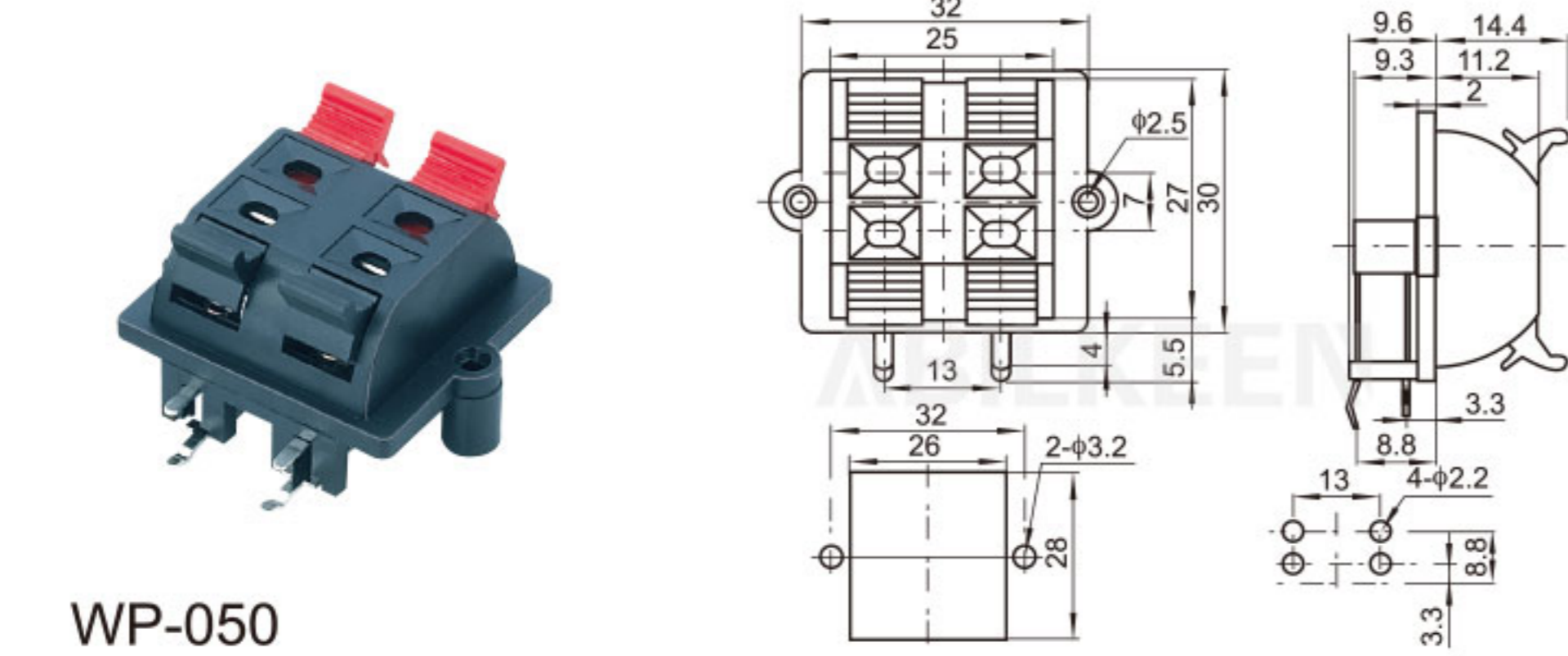

WP-050

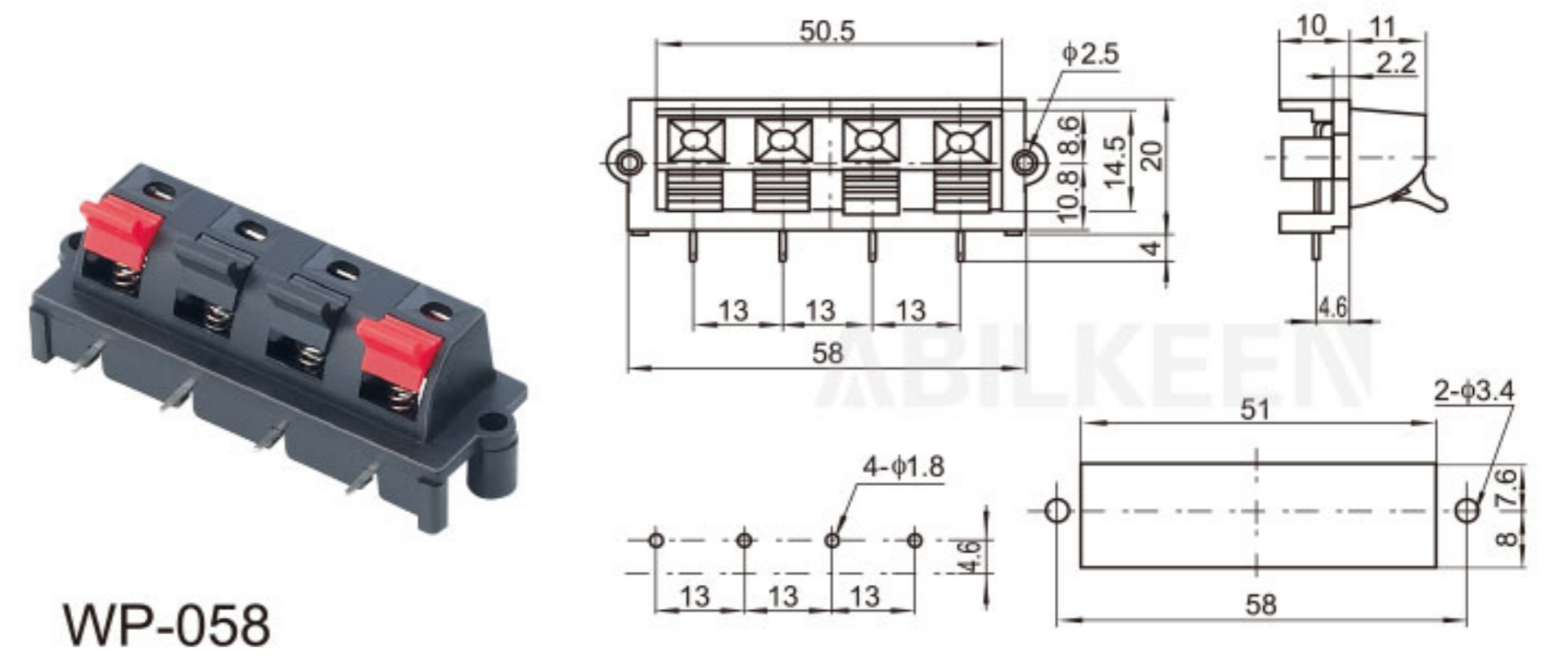

WP-058

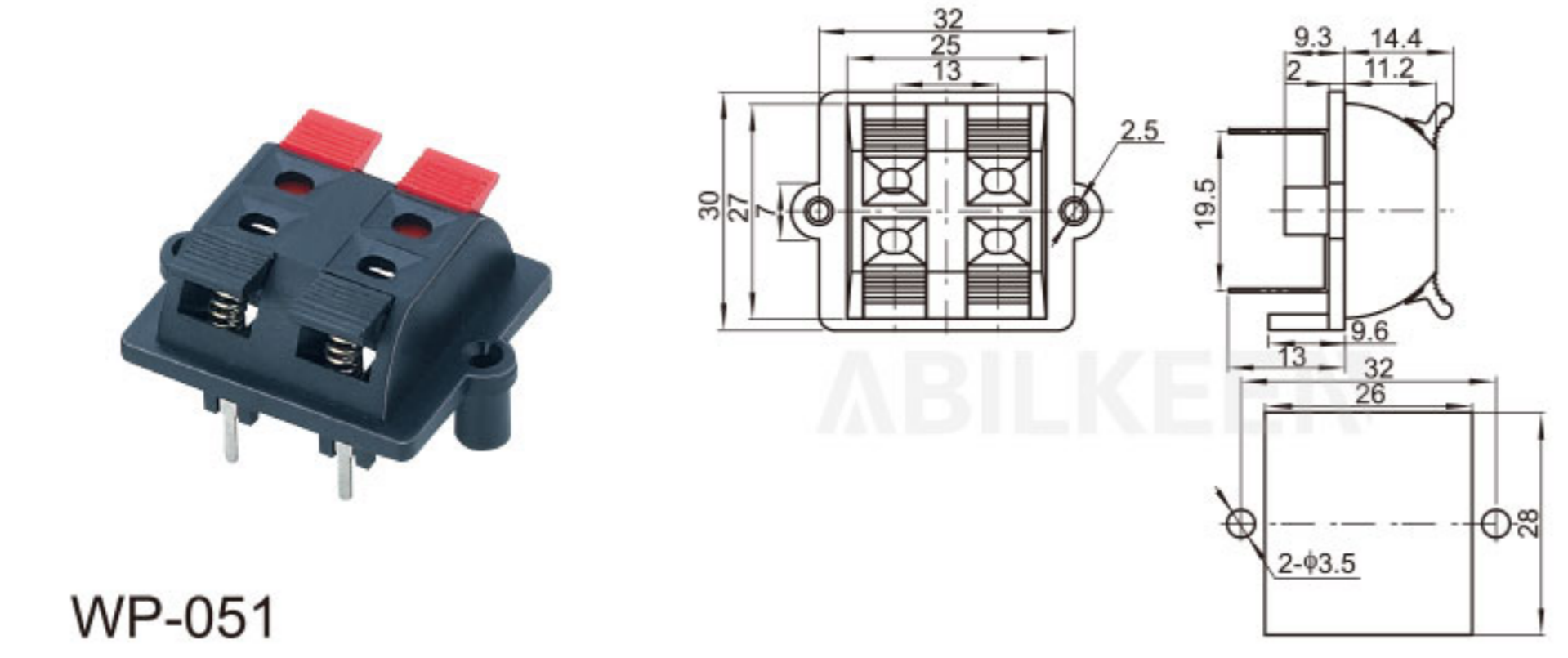

WP-051

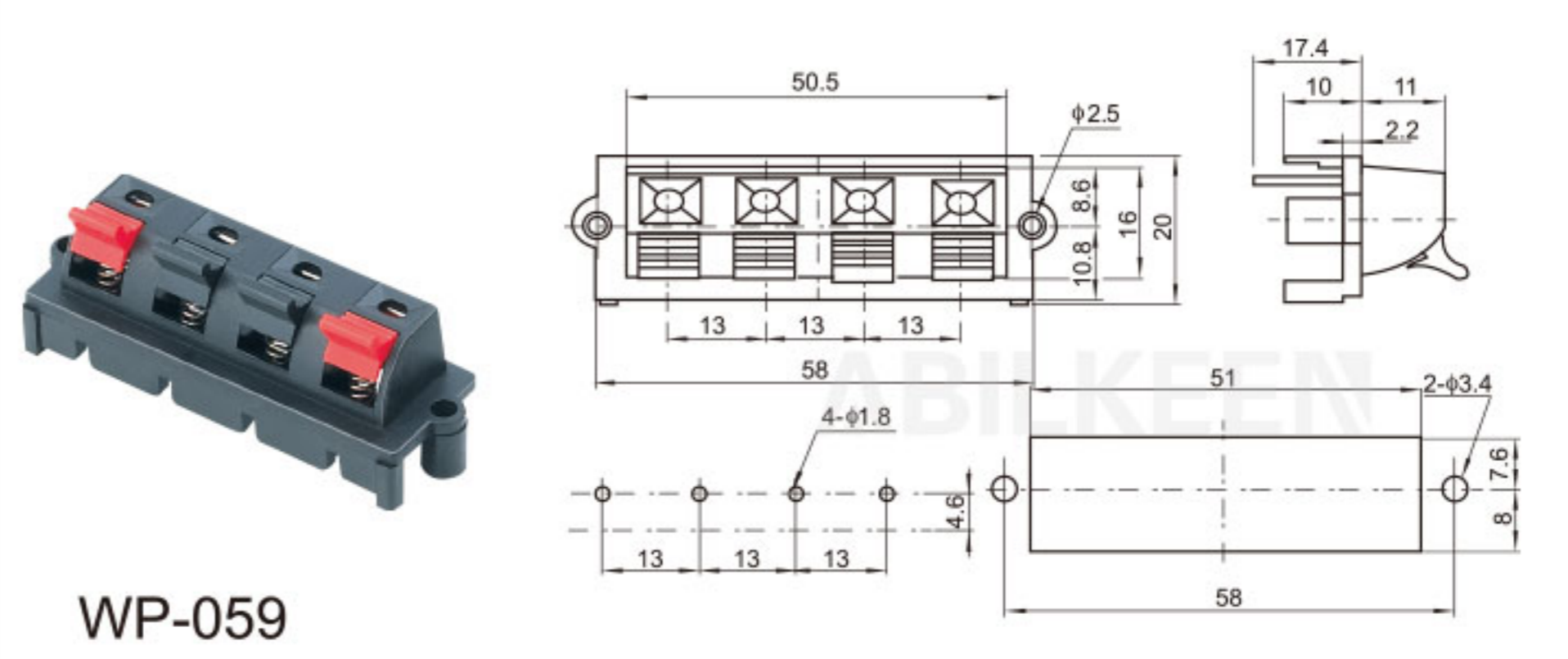

WP-059

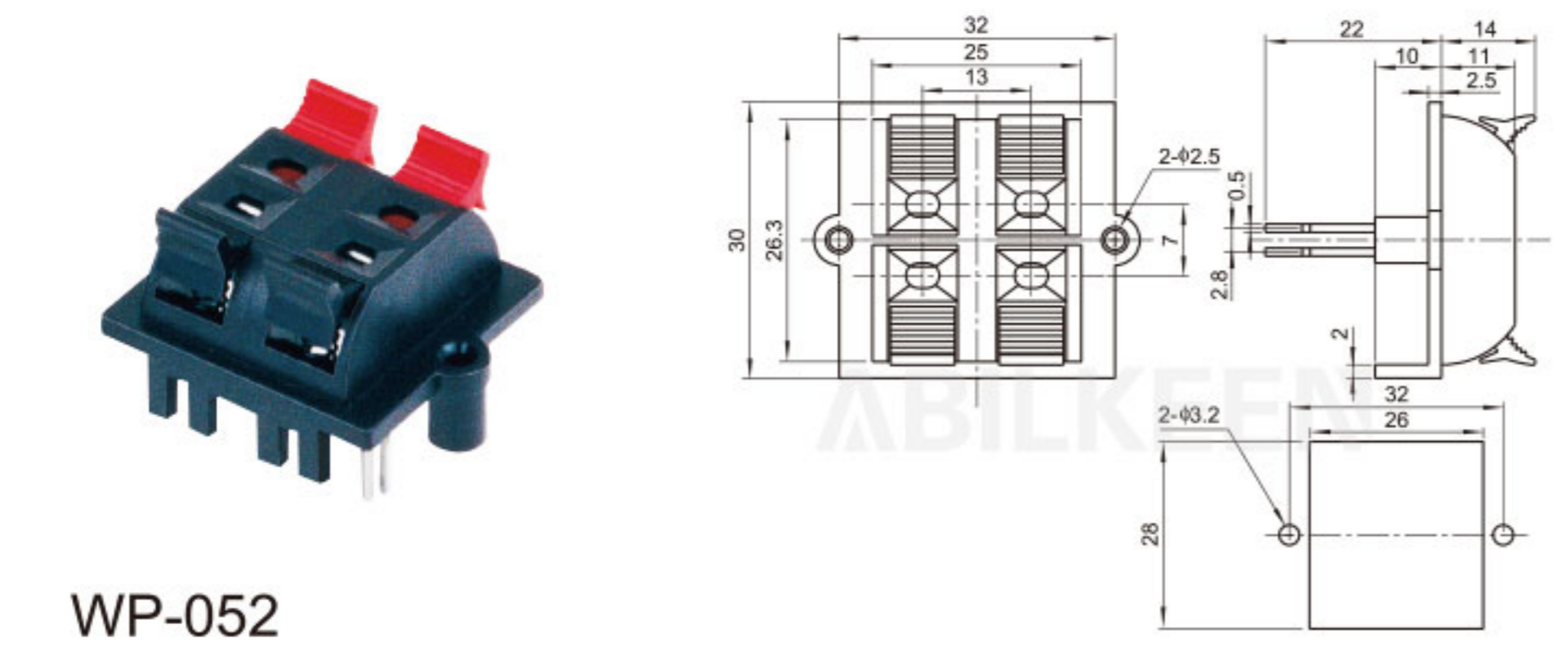

WP-052

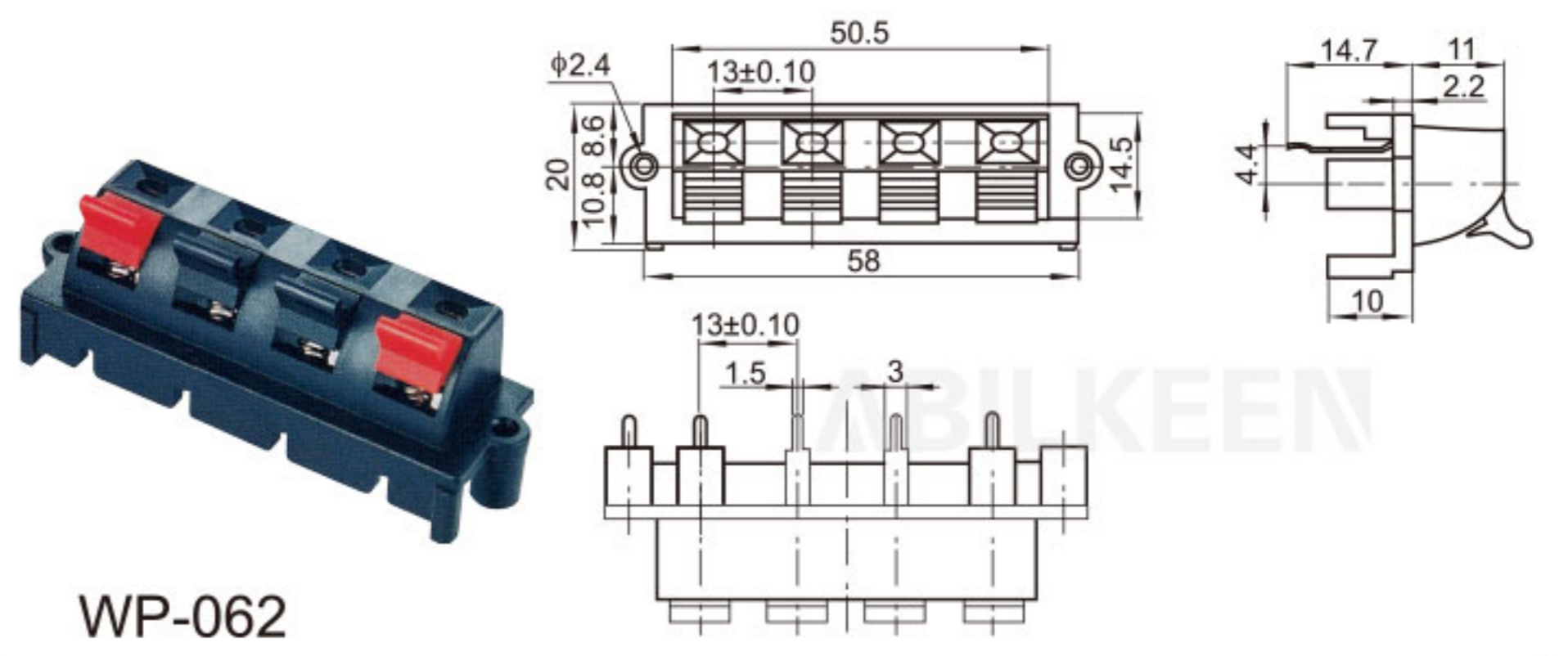

WP-062

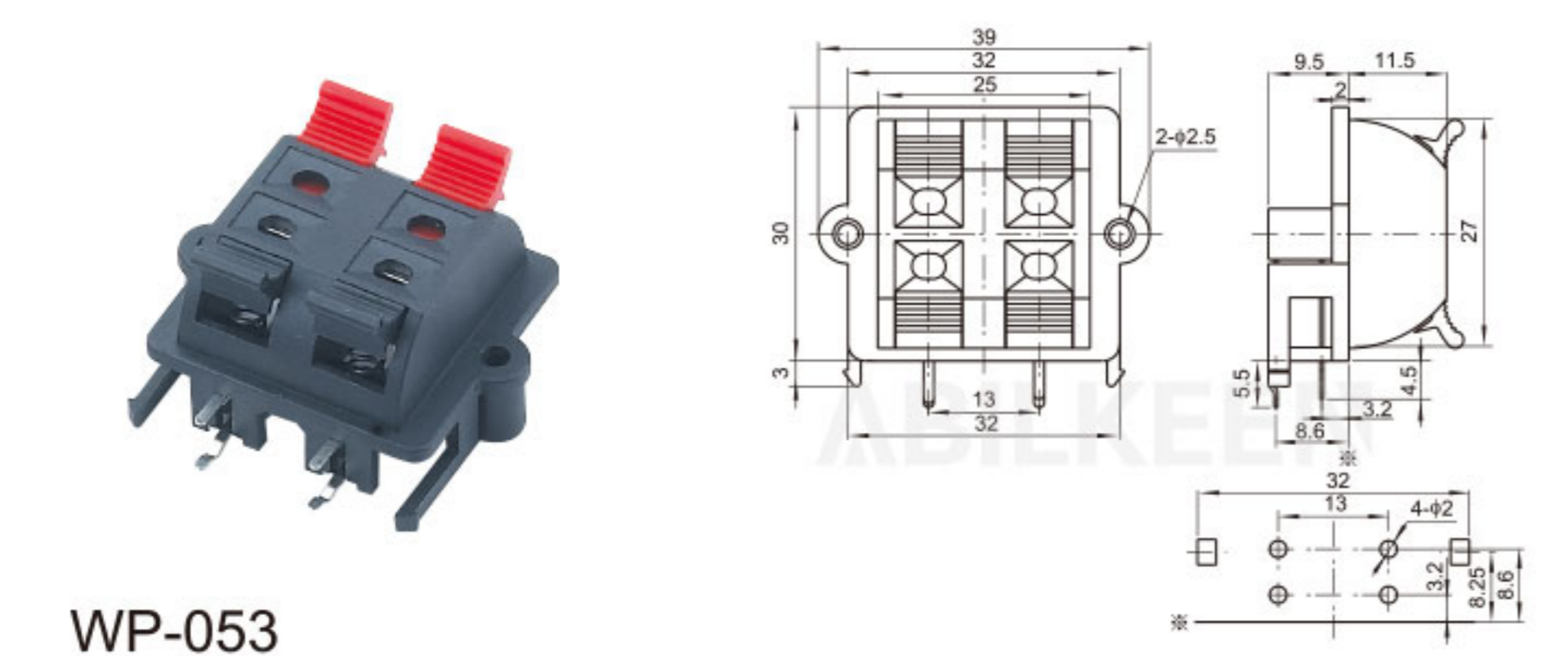

WP-053

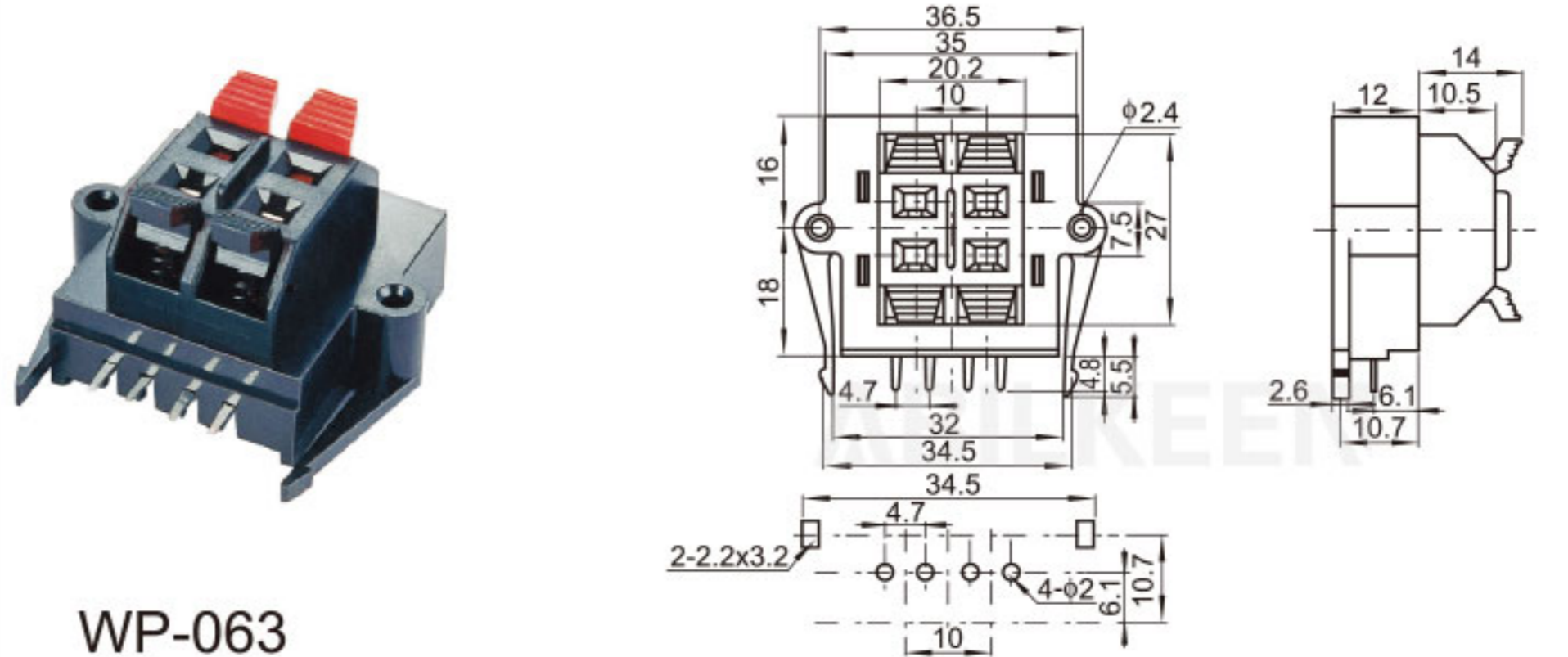

WP-063



WP-065

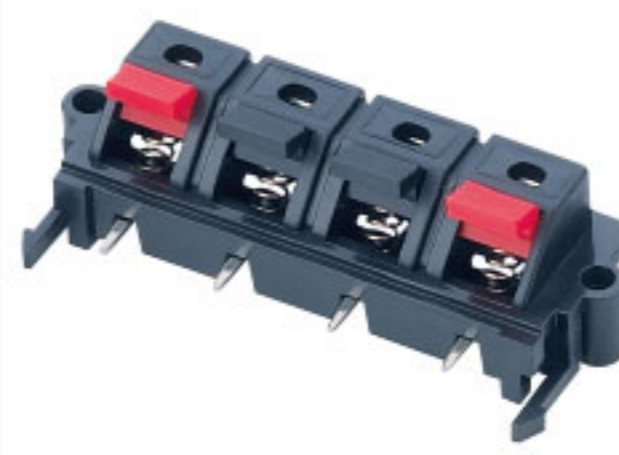
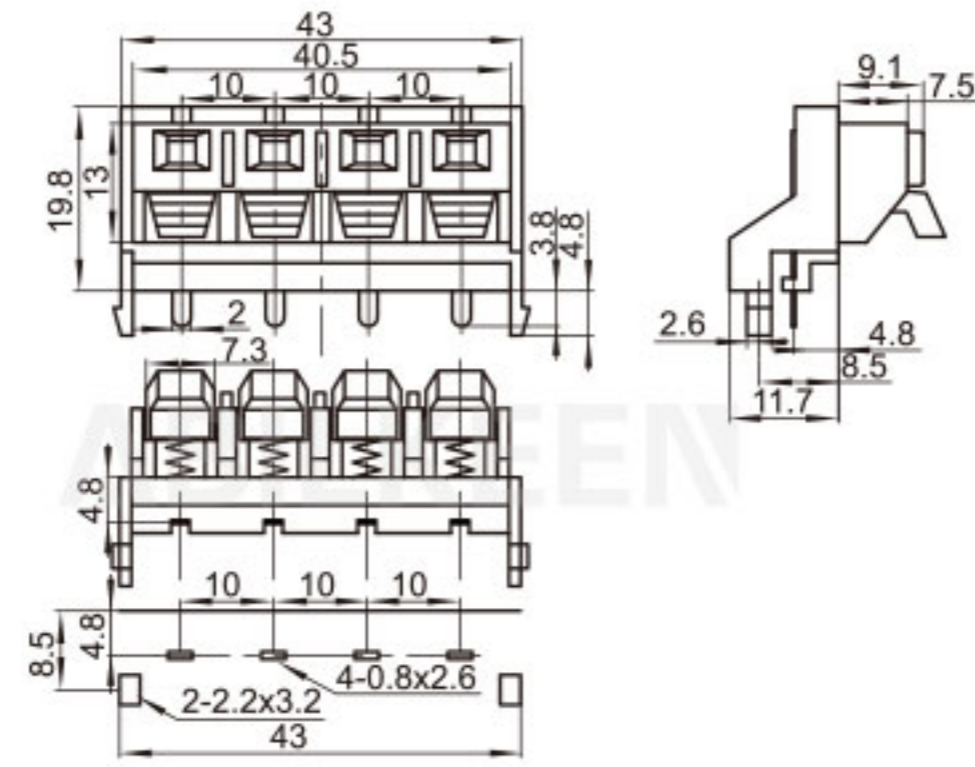

WP-075

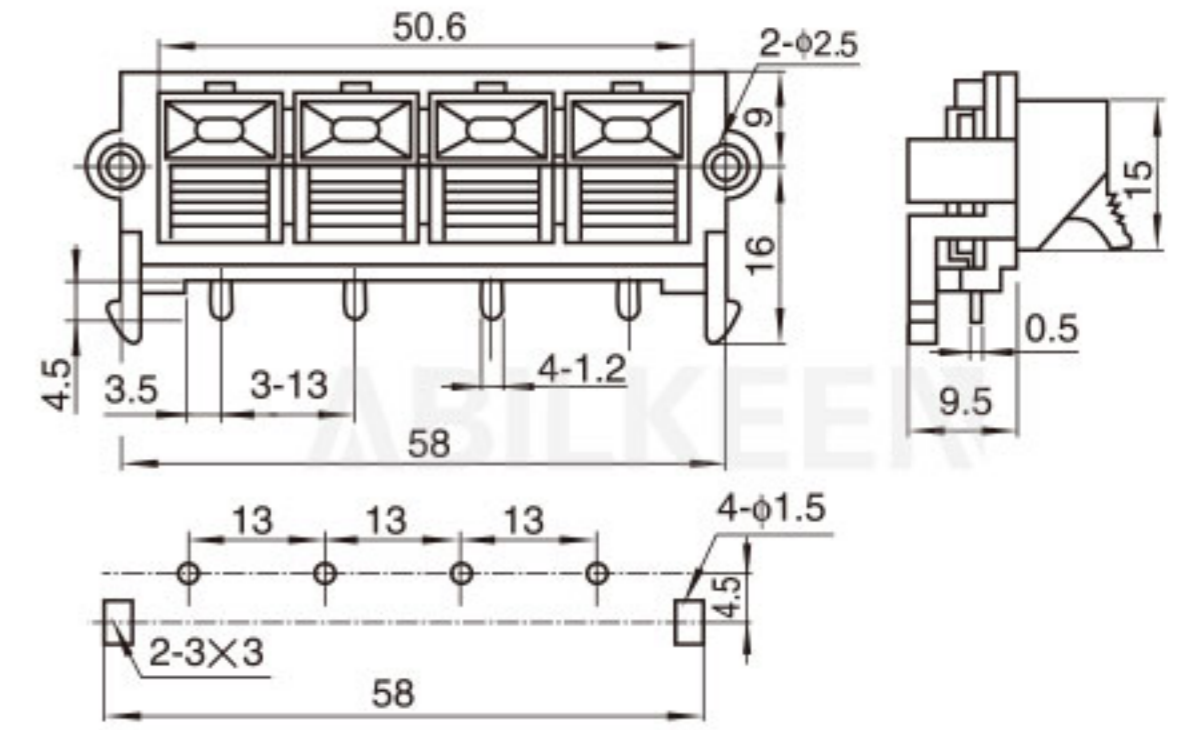

WP-066

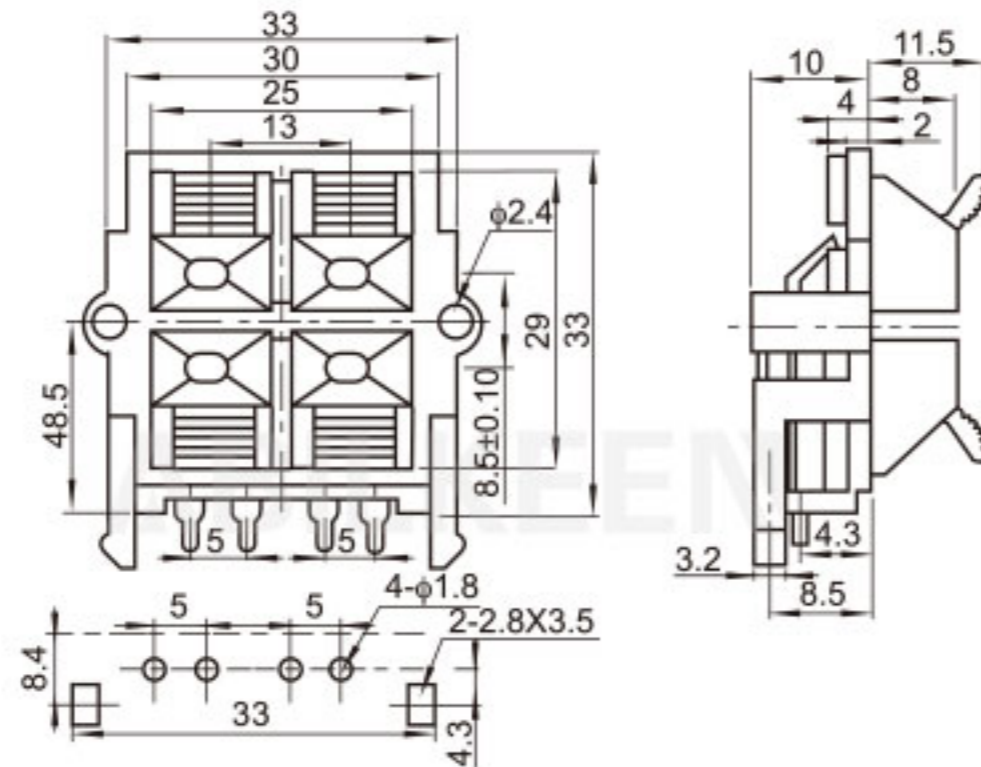

WP-076

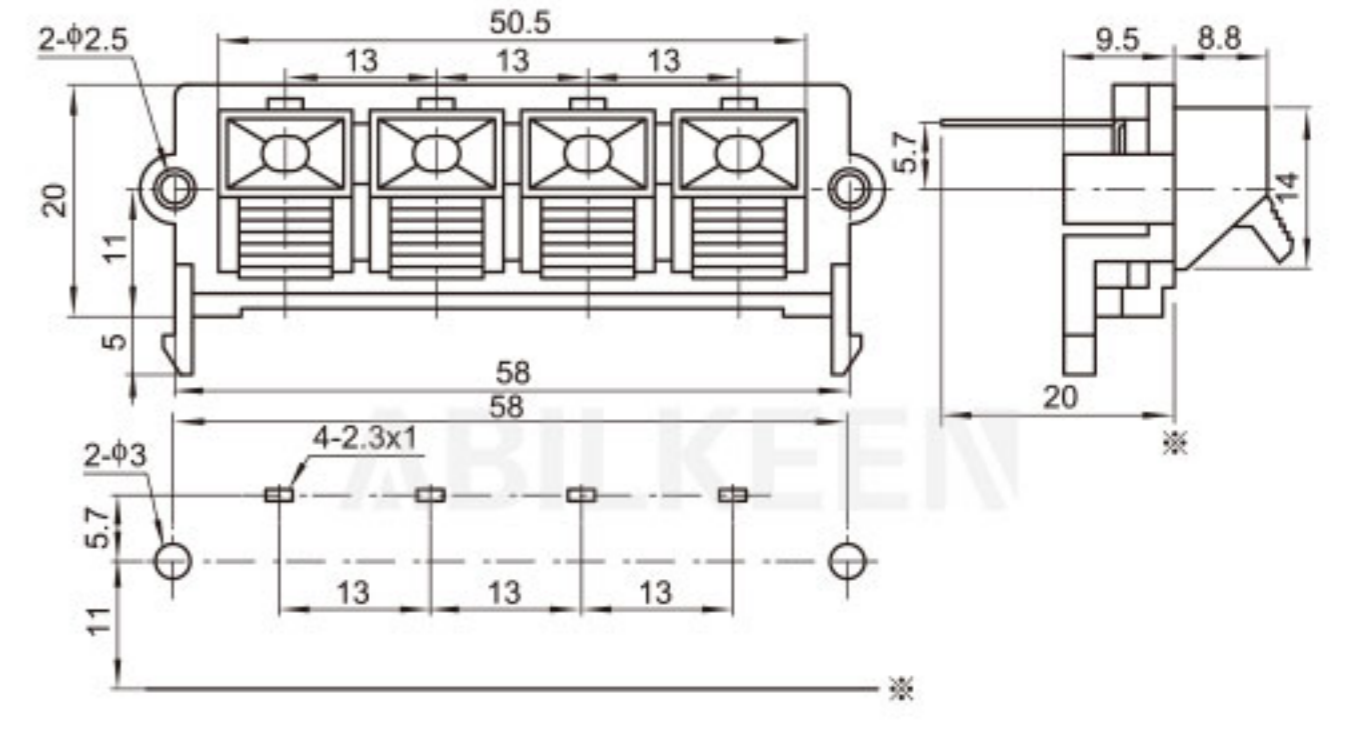

WP-067

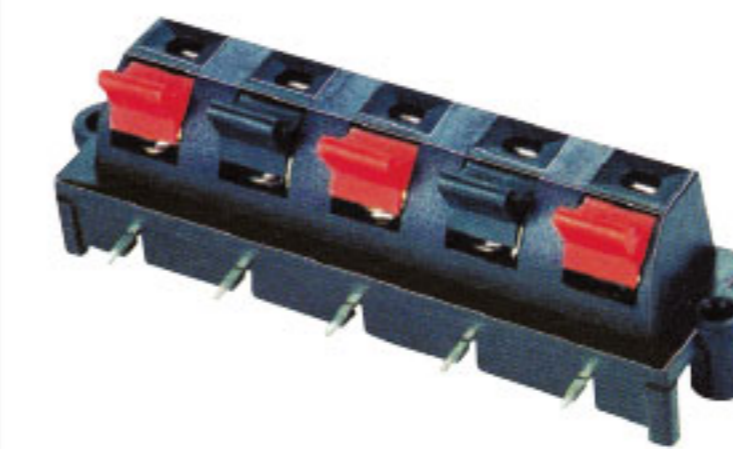
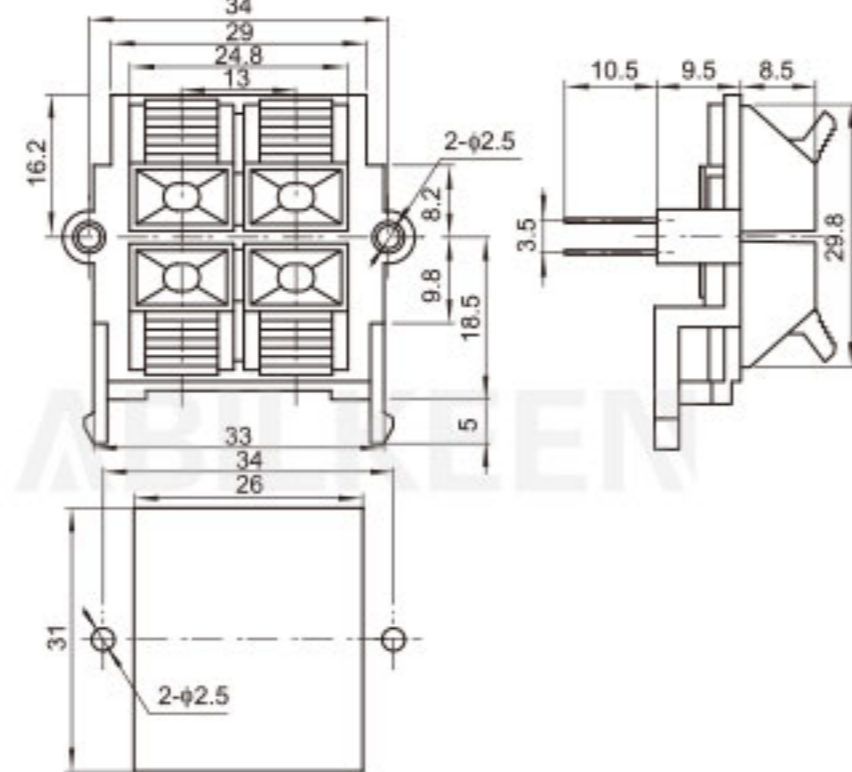

WP-080

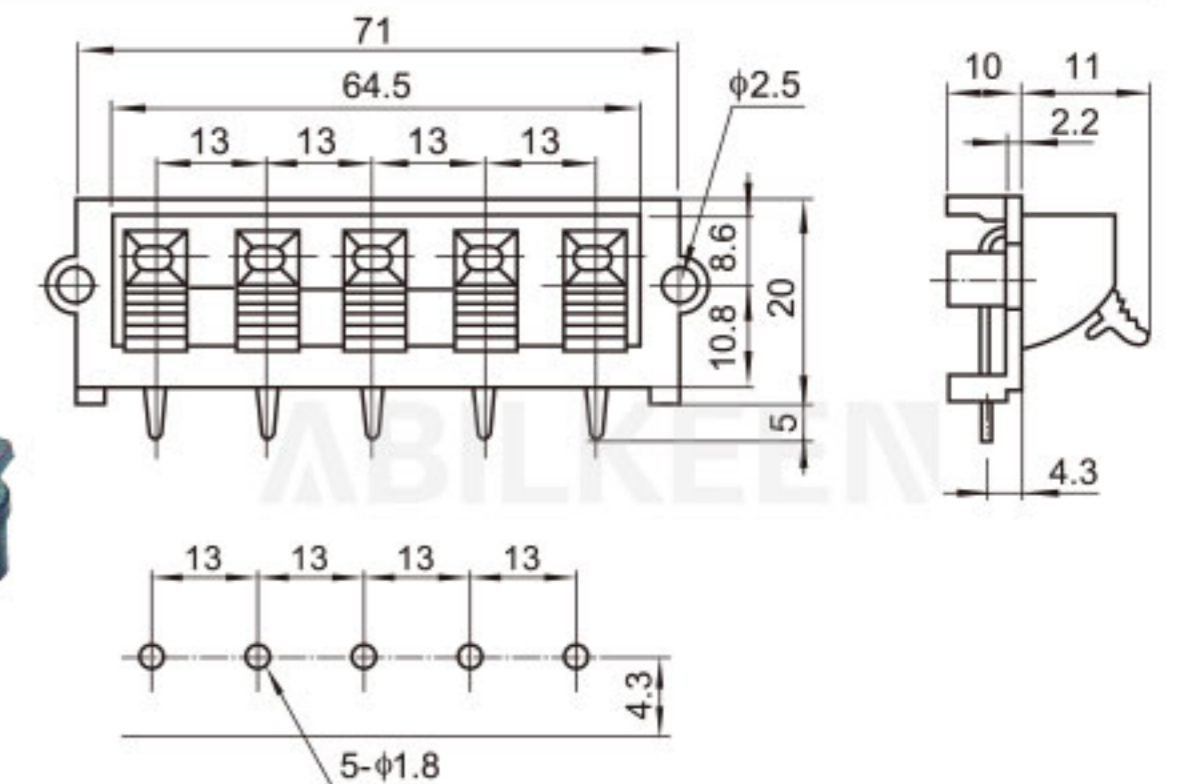

WP-071

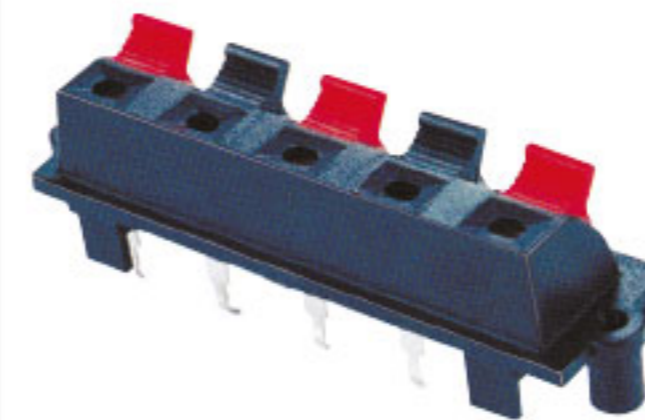
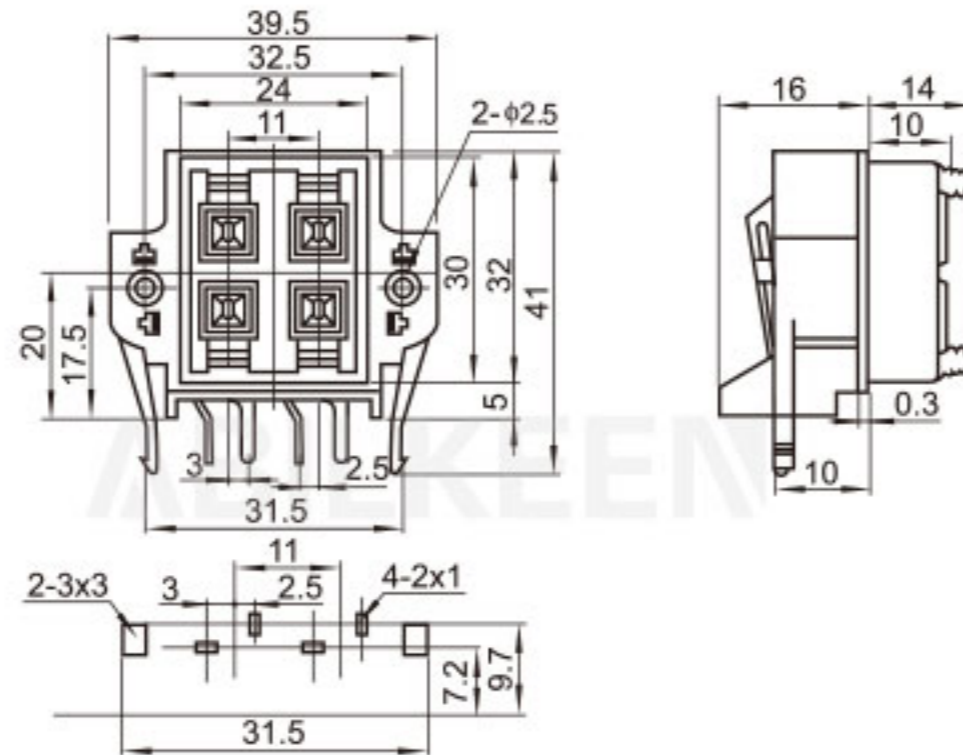

WP-081

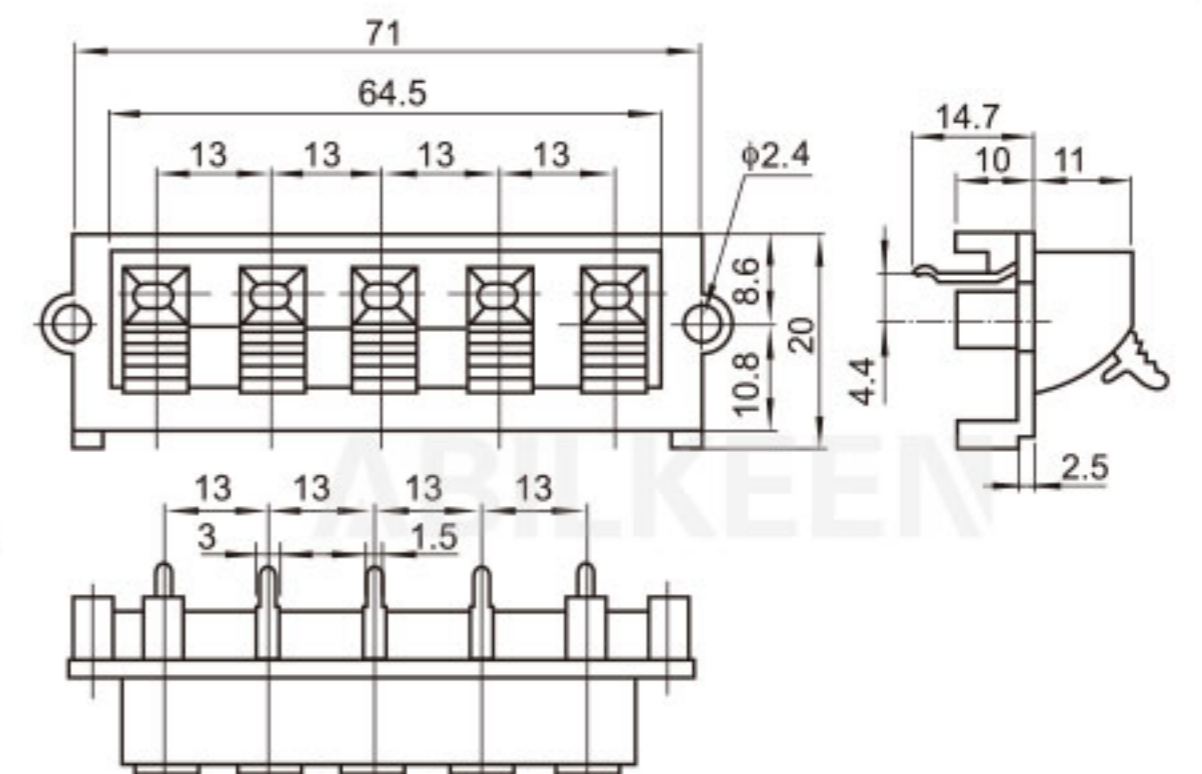

WP-073

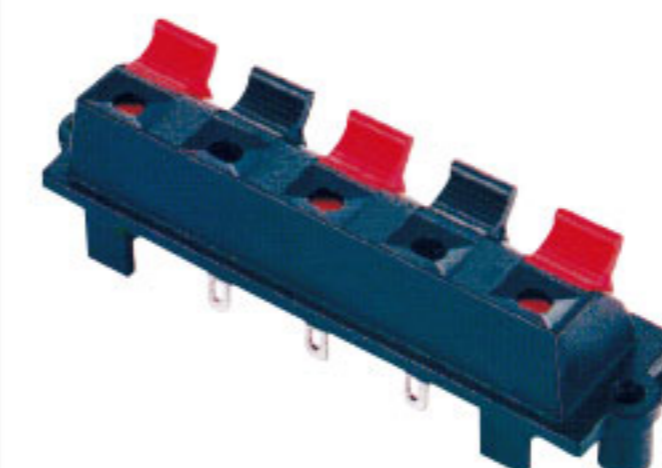
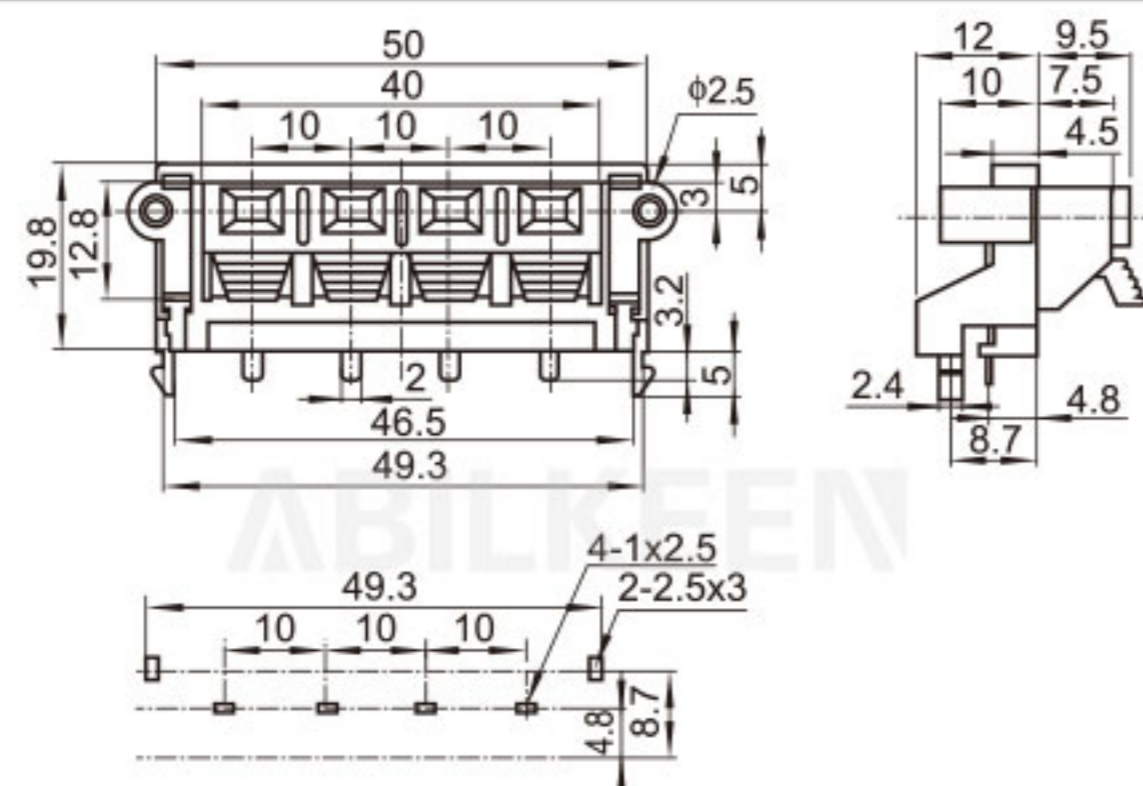

WP-082

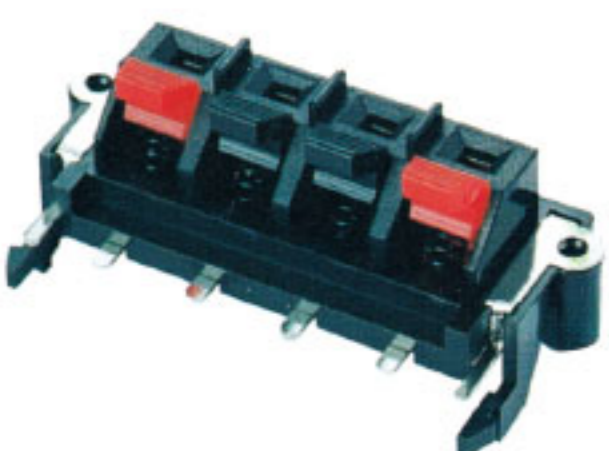
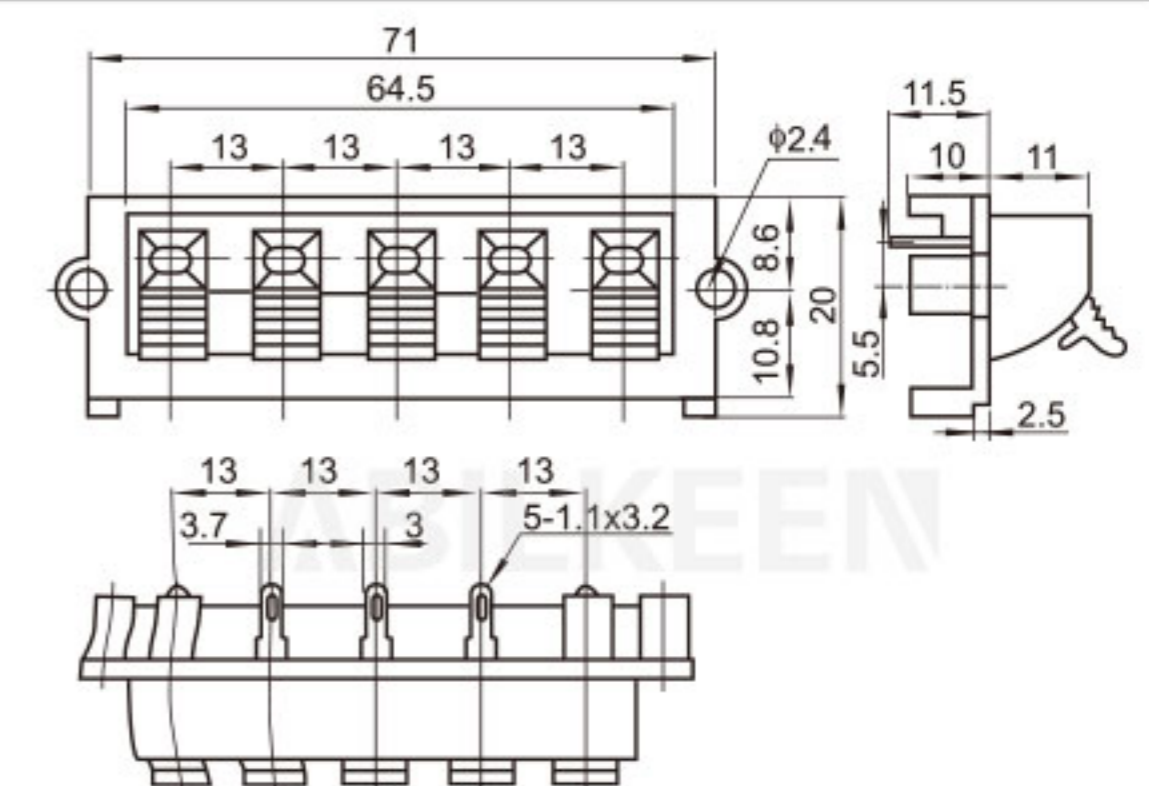

WP-074

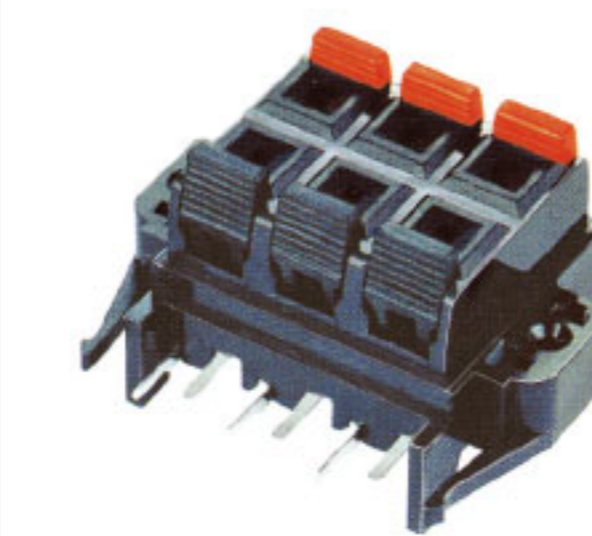
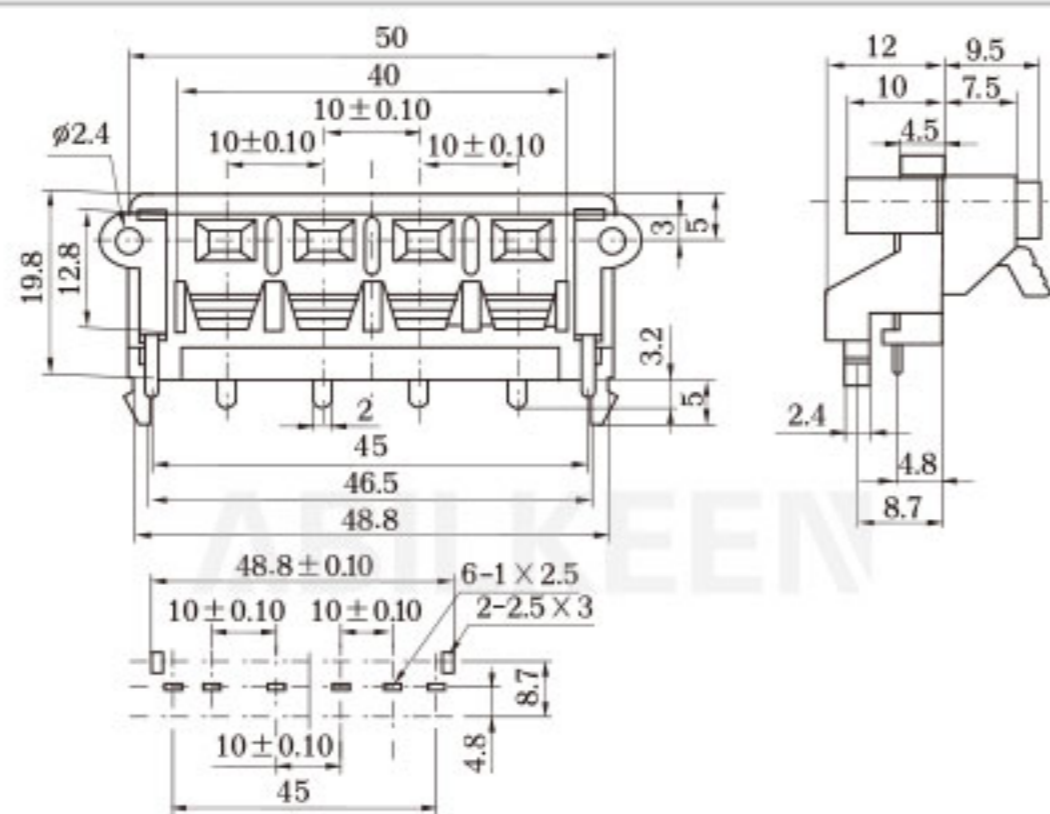

WP-083

